

Hydro BioScience, LLC
414 Century Court
Piney Flats, TN 37686
(888)-500-5011 / (423) 538-9202 (fax)
www.hydro-bioscience.com

HYDRO BIOSCIENCE™

180W AND 60W SOLAR SHORE POWER ALGAE MANAGEMENT SYSTEM

INSTALLATION & OPERATIONS MANUAL

!SAVE THESE INSTRUCTIONS!

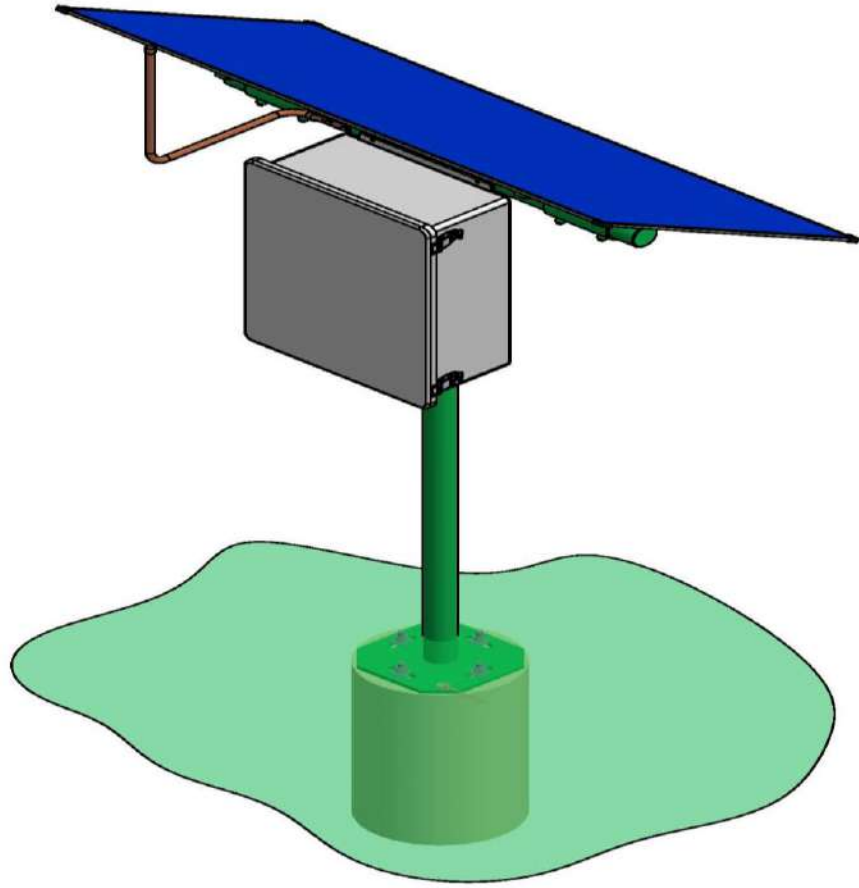



Throughout this manual; look for this symbol. It means BE ALERT – YOUR SAFETY IS INVOLVED. If you do not follow these safety instructions, personal injury or property damage may occur.

IMPORTANT: READ THIS MANUAL FROM START TO FINISH BEFORE STARTING ANY CONSTRUCTION OR ASSEMBLY OF PRODUCT! EVERY DETAIL IS IMPORTANT TO SUCCESSFULLY INSTALLING AND OPERATING THIS SYSTEM.





Table of Contents

Introduction	3
Important Safety Instructions	3
Tools Required for Installation	5
Parts List and Exploded View	5
Supplies and Parts Required But Not Included	6
How To Install And Align The Solar Panel	6
Setting The Tilt Of The Solar Panel	18
Charger Controller Operations	19
Troubleshooting	21
Maintenance	22
Preparing for Winter Storage	22
Retrieving from Winter Storage	22
Commissioning Check List	23
APPENDIX-A – Finding True South	24
Warranty	25
Contact Information	25

Introduction

Congratulations! You have purchased an environmentally safe POWER GENERATING AND ENERGY STORAGE system designed to run on clean, solar power, which then powers your applications. The solar panel system runs your device(s) and charges the system's deep cycle Absorbed Glass Mat (AGM) batteries during the day. At nighttime, the batteries continue to run your device(s).

Important Safety Instructions

1.  **REDUCE BODILY INJURY RISK WHEN HANDLING BULKY AND/OR HEAVY COMPONENTS BY USING A 2-PERSON INSTALLATION TEAM. A second person should help to lift and handle these components.**
2.  **DANGER: RISK OF ELECTRIC SHOCK! DO NOT TOUCH ANY UNINSULATED SOLAR PANEL OUTPUT WIRING OR CHARGER OUTPUT CONNECTOR, BATTERY CONNECTOR, OR BATTERY TERMINALS.**
 - 2.1. The solar panel can develop voltages greater than 42Vdc, which poses a shock and/or electrocution hazard. Always wear electrically non-conductive gloves when handling the Solar Panel's output leads.
 - 2.2. Avoid shorting the Solar Panel's output leads together or across a conductive object such as a screw driver shaft.
 - 2.3. Install panel and wiring during DRY weather conditions. Never install system while the weather is raining or in any way, precipitating.
3.  **WARNING - RISK OF EXPLOSIVE GASES. WORKING WITH A LEAD-ACID BATTERY IS DANGEROUS. EXPLOSIVE GASES DEVELOP DURING NORMAL BATTERY OPERATION. READ THIS MANUAL EACH TIME AND MAKE CERTAIN YOU FULLY UNDERSTAND IT AND FOLLOW THE SAFETY AND OPERATING INSTRUCTIONS AT ALL TIMES.**
 - 3.1. To reduce risk of battery explosion, follow all safety instructions below and those published by the battery manufacturer. Review cautionary markings on vehicle or equipment containing the battery.
 - 3.2. Use of an attachment not recommended or sold by the Solar Panel System manufacturer may result in a risk of fire, electric shock or injury to persons.
 - 3.3. Do not operate this Solar Panel System if it has received a sharp blow, was dropped or otherwise damaged in any manner. Refer to a qualified service agent.
 - 3.4. Charger Controller contains no serviceable parts. If it fails during its warranty period, contact your dealer for a warranty replacement.
4.  **PERSONAL PRECAUTIONS WHILE WORKING WITH BATTERIES**
 - 4.1. Have someone within range of your voice to come to your aid if needed.
 - 4.2. Have plenty of fresh water and soap nearby in case battery acid contacts your skin, clothing or eyes. Wear eye and clothing protection and avoid touching eyes.
 - 4.3. If battery acid contacts skin or clothing, wash immediately with soap and water.
 - 4.4. If acid enters eye, immediately flush eye with running cold water for at least 10 minutes. Get medical attention immediately.
 - 4.5. NEVER smoke or allow a spark or flame in vicinity of battery.
 - 4.6. Be extra cautious not to drop metal tools onto battery. It might spark or short circuit battery or other electrical part that may cause an explosion.
 - 4.7. Remove personal metal items such as rings, necklaces, watches, etc. Batteries can produce a short-circuit current high enough to weld such items causing a severe burn.
 - 4.8. NEVER charge a frozen battery. Thaw it out for safer and more efficient charging.
5.  **ELECTRICAL CONNECTION SAFETY PRECAUTIONS**
 - 5.1. Do not make any electrical connections until specifically instructed to do so in this manual AND AT THE PRECISE TIME STATED IN THIS MANUAL.
 - 5.2. The Solar Panel will most likely be assembled by you in daylight which means the Solar Panels are generating electricity. If a connection is made at the wrong time, or out of sequence, the energy produced by the Solar Panel may damage connector

pins in the process of making the connection – THIS DAMAGE RESULTS IN A NON-WARRANTY REPLACEMENT OF THE PART(s).

Tools Required for Installation

- Digging Shovel
- Post hole digger
- Container to mix concrete such as a wheel barrow
- 12 inch Dia. x 18 inch long Concrete Form
- Torpedo Level
- 14" long board for "Strike Off" of concrete
- Concrete Hand Float for finishing the concrete and trowel
- High Quality Compass with angle indicating ring
- Angle Finder for setting Solar Panel Elevation
- Heavy hammer or sledge hammer for driving grounding rod (if installing Lightning Rod Accessory Kit)
- Adjustable wrench or socket wrench with sockets
- Phillips Screwdriver and Flat Point Screwdriver

Parts List and Exploded View

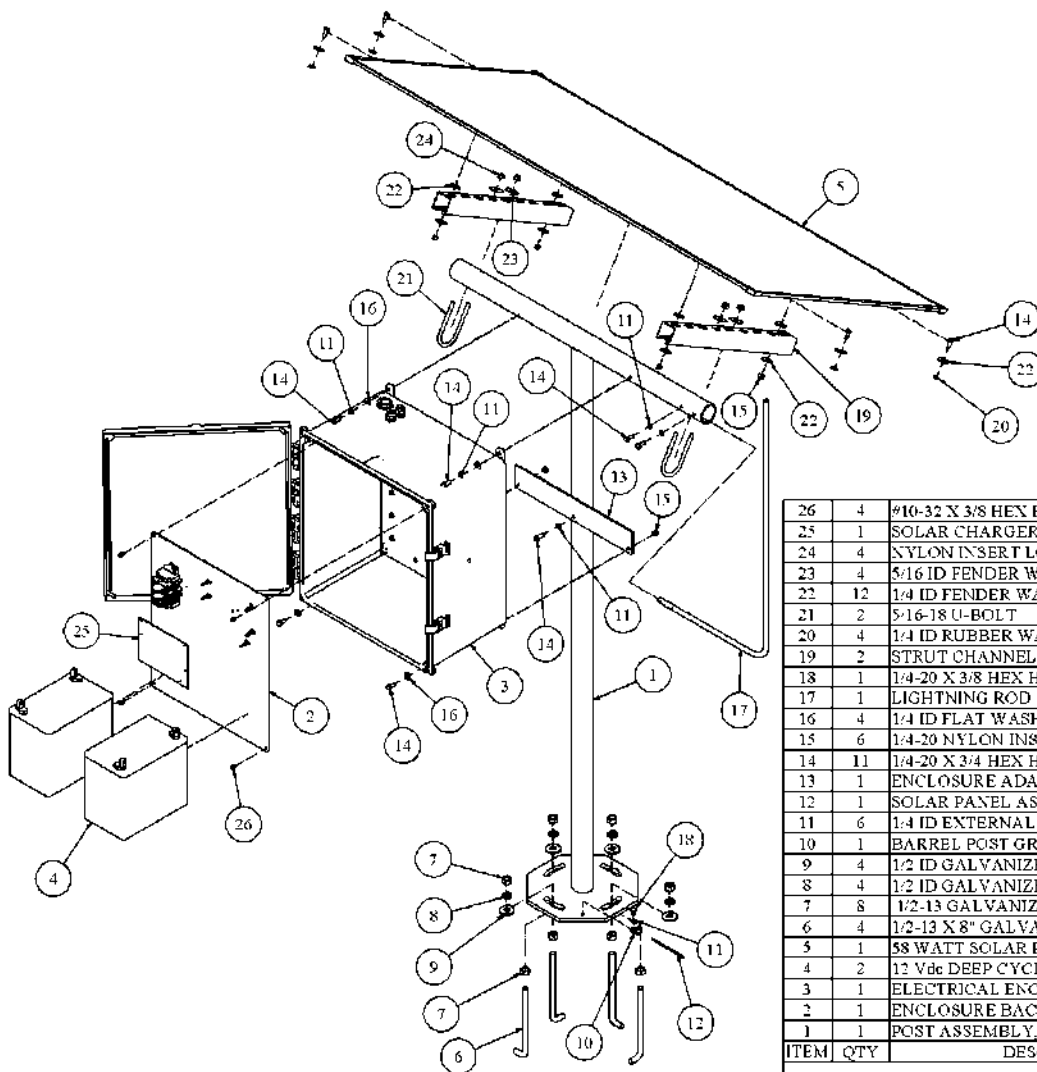

26	4	#10-32 X 3/8 HEX HEAD SCREW	HDW068
25	1	SOLAR CHARGER	PCA118
24	4	NYLON INSERT LOCKNUT, 5/16-18	HDW188
23	4	5/16 ID FENDER WASHER	HDW187
22	12	1/4 ID FENDER WASHER	HDW181
21	2	5/16-18 U-BOLT	HDW185
20	4	1/4 ID RUBBER WASHER	HDW173
19	2	STRUT CHANNEL	BKT062
18	1	1/4-20 X 3/8 HEX HEAD SCREW	HDW179
17	1	LIGHTNING ROD	CPT034
16	4	1/4 ID FLAT WASHER	HDW153
15	6	1/4-20 NYLON INSERT LOCKNUT	HDW154
14	11	1/4-20 X 3/4 HEX HEAD SCREW	HDW170
13	1	ENCLOSURE ADAPTER PLATE	BKT067
12	1	SOLAR PANEL ASM GROUND WIRE	WCB112
11	6	1/4 ID EXTERNAL TOOTH LOCKWASHER	HDW172
10	1	BARREL POST GROUND CLAMP	HDS110
9	4	1/2 ID GALVANIZED FLAT WASHER	HDW151
8	4	1/2 ID GALVANIZED LOCK WASHER	HDW149
7	8	1/2-13 GALVANIZED HEX NUT	HDW150
6	4	1/2-13 X 8" GALVANIZED L BOLT	HDW148
5	1	58 WATT SOLAR PANEL	SLP005
4	2	12 Vdc DEEP CYCLE BATTERY	BAT010
3	1	ELECTRICAL ENCLOSURE	ENC100
2	1	ENCLOSURE BACK PANEL	CHS004
1	1	POST ASSEMBLY, SOLAR PANEL	CHS001
ITEM	QTY	DESCRIPTION	PART NUMBER

HYDRO BIOSCIENCE, LLC

414 CENTURY COURT • PINEY FLATS, TN 37686, USA • Tel: 001-888-500-5011 • WWW.HYDRO-BIOSCIENCE.COM

Supplies and Parts Required But Not Included

- 12” Dia. x 18” long Concrete Form
- Concrete Mix – Volume = .044 cubic yards. Approximately (8) 60 lb bags or (6) 80 lb bags needed
- 5/8” Dia. x 6 ft long Grounding Rod
- 5/8” Brass Ground Clamp for above Rod
- Spray Paint for marking sun direction
- Loctite Thread Locker (#2440 Medium Strength)
- Glass cleaner and paper towels for cleaning the Solar Panel

How To Install and Align The Solar Panel

1. Determine where to locate the Solar Panel System. Keep in mind:
 - a. Location must provide continuous direct sunlight to the panel at all times. **AVOID ALL SHADOWS! Including shadows that may appear during the day!** Even a small shadow ‘may’ have the potential to reduce solar panel output to 0%.

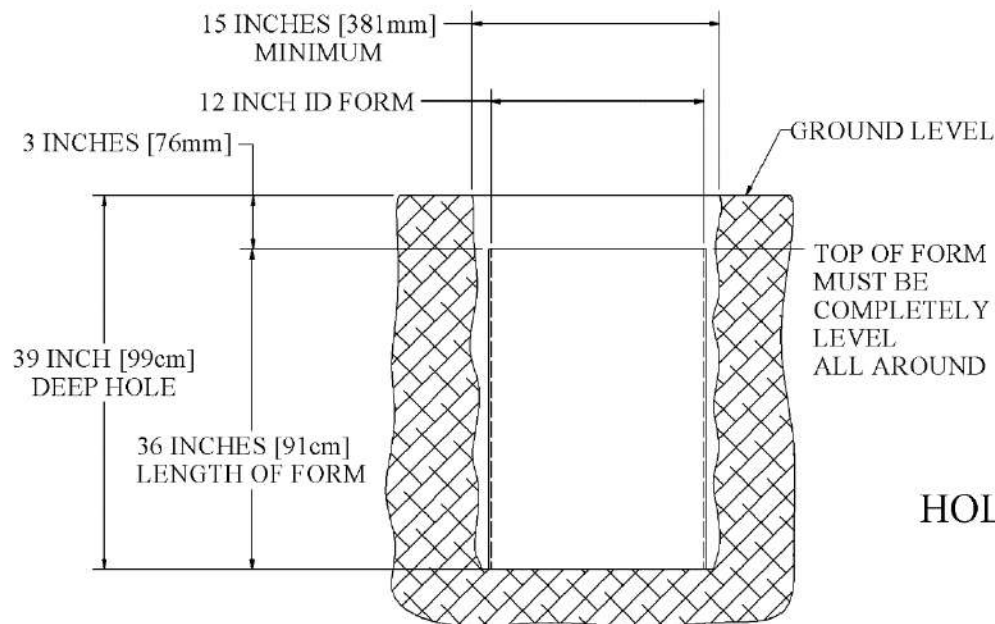

FIGURE 1
HOLE PREPARATION

2. Refer to Figure 1:
 - a. Purchase a round 12” (30cm) ID concrete form and cut the form to 36” (91cm) in length.
 - b. Dig a hole 15” (38cm) minimum, in diameter, and 39” (91cm) deep. Place the round concrete form in the hole.

IMPORTANT: Ensure the form is completely level all the way around. (Refer to Figure 1).

IMPORTANT: BEFORE MOVING ONTO THE NEXT STEP, DETERMINE THE DIRECTION OF TRUE SOUTH BY USING THE MAPS, READING THE INSTRUCTIONS FOUND IN APPENDIX-A TITLED ‘FINDING TRUE SOUTH’ AND USING A GOOD, HIGH QUALITY COMPASS. ONCE THE DIRECTION HAS BEEN ESTABLISHED, USE A CAN OF SPRAY PAINT AND MARK A LINE FROM THE HOLE JUST CREATED, TOWARDS THE DIRECTION OF TRUE SOUTH!!

3. Referring to Figure 2, prepare the L-Bolt Template Assembly. **(BE SURE TO HAVE FOLLOWED THE IMPORTANT INSTALLATION INSTRUCTION OF THE PREVIOUS STEP BEFORE MOVING TO THIS STEP.)** Now that the direction of True South has been determined and the direction has been spray painted onto the ground, orient one template arm of the L-Bolt Template in the direction of True South when inserting the L-Bolt Assembly into the concrete.
Caution: Do not use Loctite Threadlocker #2440 during this step.

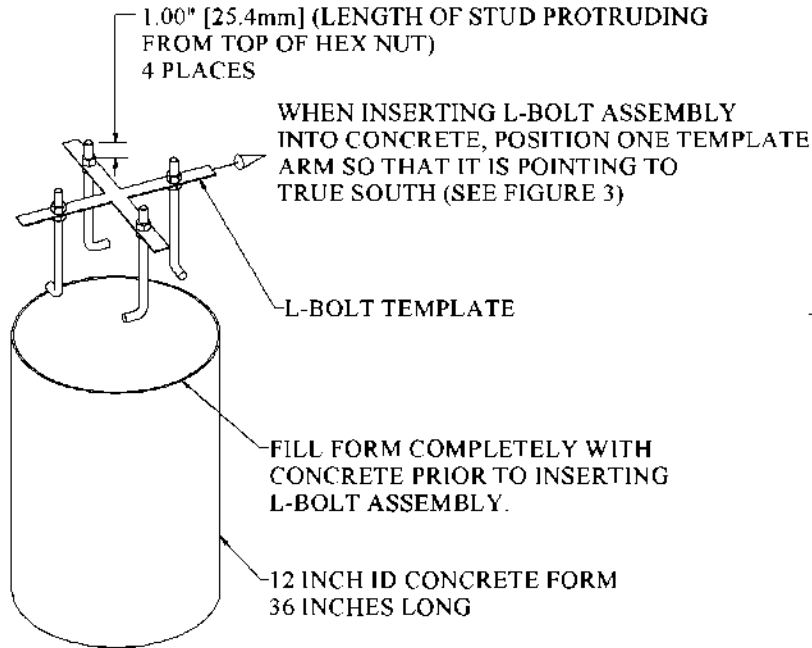

FIGURE 2

4. Fill the round concrete form completely with concrete. Work a shovel in and out of the concrete to eliminate air pockets and to compact the mix. Add more mix as needed to fill to the top of the form.

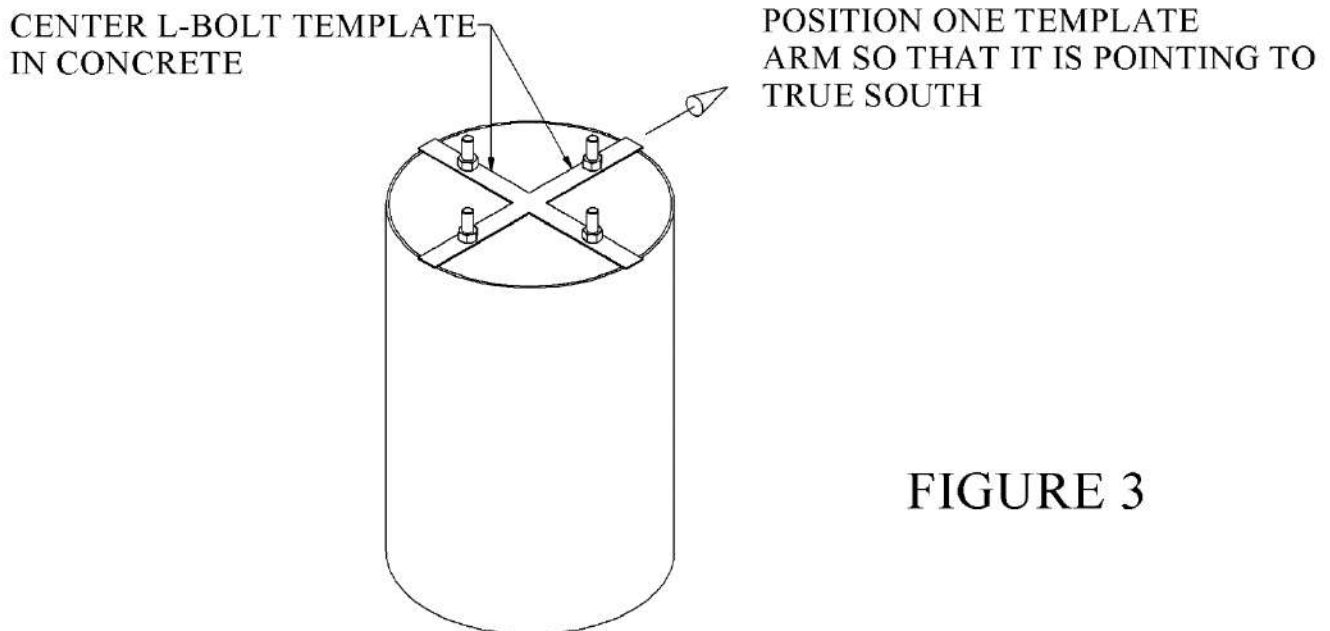

FIGURE 3

5. “Strike off” by placing a 14” long straight piece of wood (such as a 2”x4”) across the top edge and middle of the form. Rotate the board all the way around to smooth the concrete.

6. Insert the L-Bolt Assembly as shown in Figure 3 ensuring that one template arm is pointing to true south. Use a compass and the declination chart on Appendix-A to find true south. Note: **The Post Assembly Base Plate has slots which allows the assembly to be adjusted plus or minus 15 degrees. Ensure, after seating L-bolt template, that one template arm is within this range.**
7. After the concrete partially sets, remove the four (4) nuts and L-bolt template, (refer to Figure 4), and smooth the surface of the concrete. Clean concrete from the L-bolt threads and remove any ridges that are formed at the base of the bolts where they protrude from the concrete. The Post Assembly Base Plate must rest on a completely flat surface.

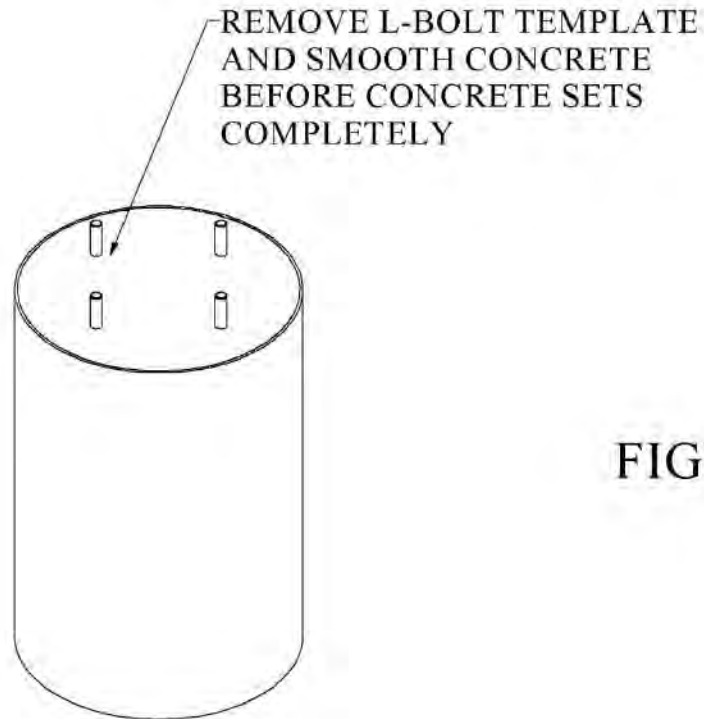
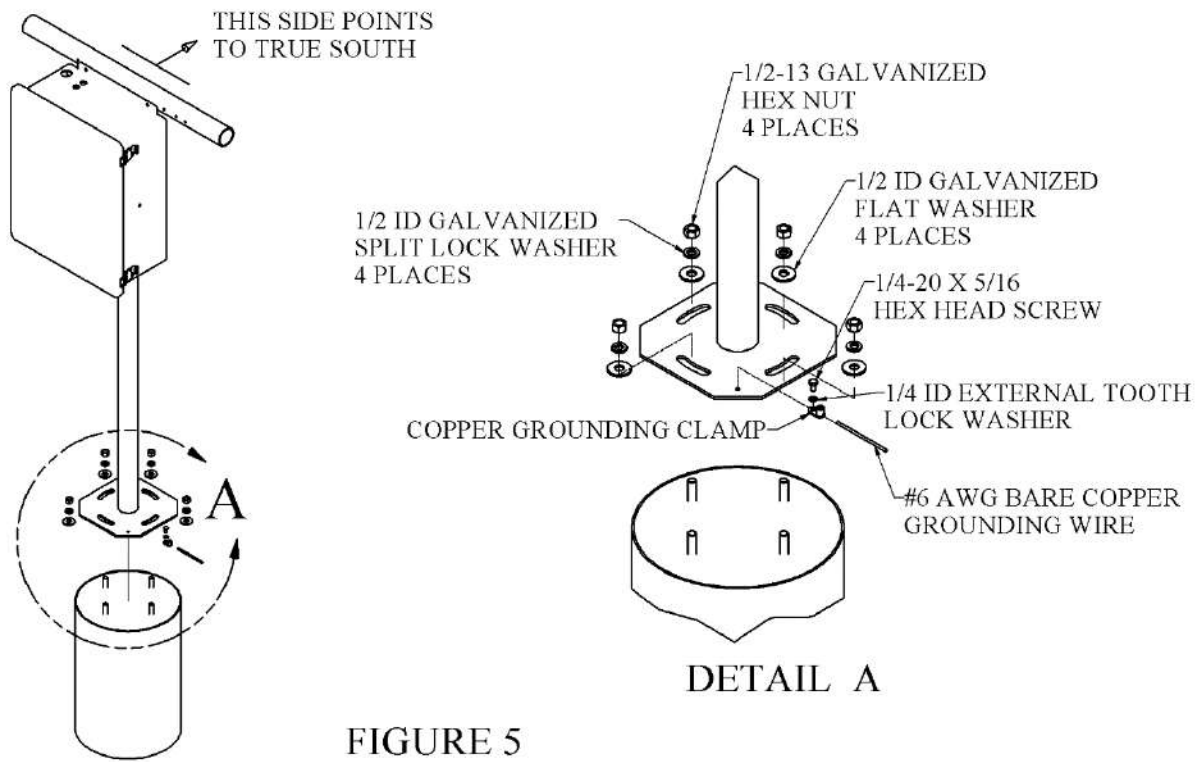

FIGURE 4

8. Allow the concrete to cure completely.



- Dig a small pocket in the ground (See Figure 6) about 3 or 4 inches deep near the copper clamp located on the Post Assembly Base Plate. Ensure the pocket breaks into the hole dug for the concrete.

Note: The 5/8" Dia. X 6' long Grounding Rod and 5/8" Brass Ground Rod Clamp shown in Figure 6 is not supplied, but easily purchased from local hardware stores or most Electrical supply stores.

Insert Brass Rod Clamp over Ground Rod about 1" from the top of the rod and securely tighten clamping screw. **Note: DO NOT MISS THIS STEP. If the rod is pounded into the ground, the end will mushroom, preventing the clamp from being installed after.**

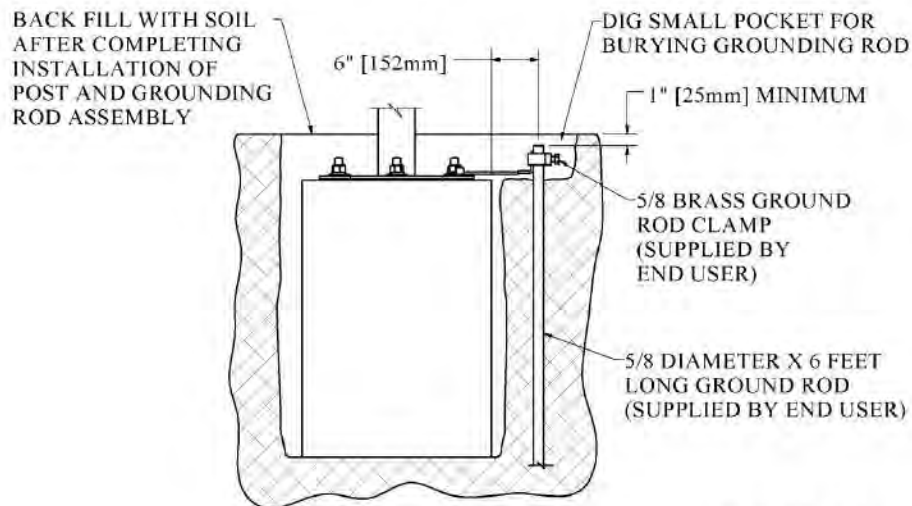



FIGURE 6

- Locate grounding rod assembly about 6" (153mm) from the concrete pad and in the pocket dug earlier. Using a heavy hammer or sledge hammer drive the rod into the ground until the top of the rod is a minimum of 1" (2.5cm) below ground. If you have trouble driving the rod in hard ground, driving the rod partly in the ground, then removing and pouring water in the hole often corrects this problem.
- Connect the Ground Wire to the Brass Ground Rod Clamp as shown in Figure 5 and 6. Connect other end of the #6 Ground Wire to the Post Base Mounting Plate threaded hole as shown in Figure 5.
-  **IMPORTANT: Using Spray Paint, completely paint and saturate the connection of the ground wire to the Brass Ground Rod Connector and Base Plate connection to prevent future corrosion to these joints. Allow to dry before proceeding to next Step.**
- Attach the Post Assembly to the L-Bolts as shown in Figure 5. Do not tighten until the post is oriented to true South. Apply Loctite Threadlocker #2440 to the threads of the L-Bolts.
- Using a compass and derived Declination Value from the Chart in Appendix-A, determine true south. **Note: Do not place the compass too close to Post Assembly - it is made of steel and will induce compass error!**
- Adjust the Post Assembly with the enclosure side facing true north. The face of the top crosspiece of the Post Assembly will be perpendicular to true south, while the ends of the top crosspiece will point East-West.
- Tighten nuts on L-bolts until the lock washers flatten and the nuts are tight.
- Backfill around the Post Base Mounting plate to ground level and compact the soil. Replace the sod.



CAUTION! Temporarily tape packing bubbles or packing foam around the vertical post opposite the enclosure for reducing the chance of breaking the Solar Panel glass if it drops

and hits the vertical post during the following installation steps. If the Solar Panel is dropped against the vertical post, permanent damage to the Solar Panel may occur!!

18. Assemble the Solar Panel to the horizontal crosspiece of the Post Assembly as shown in Figures 7 and 8.

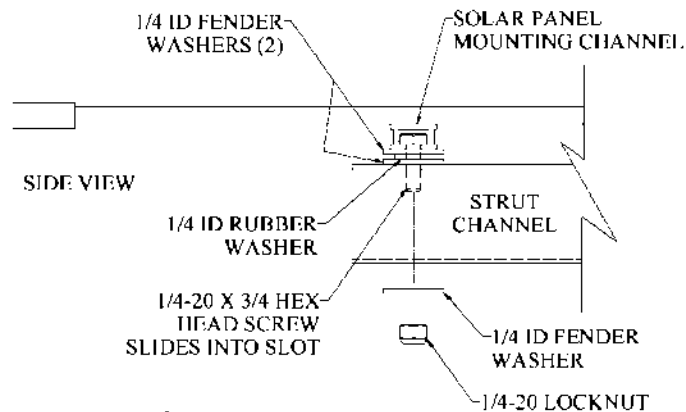
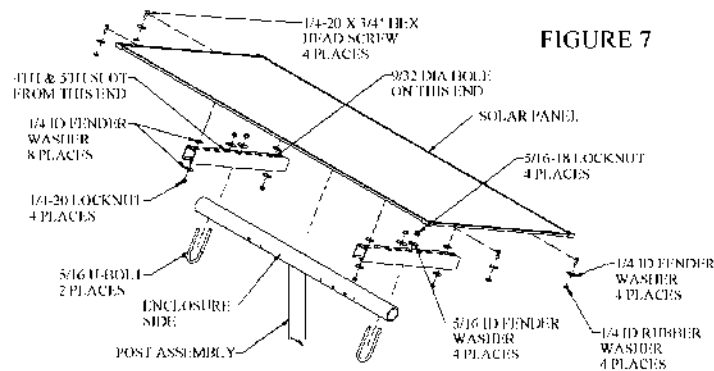
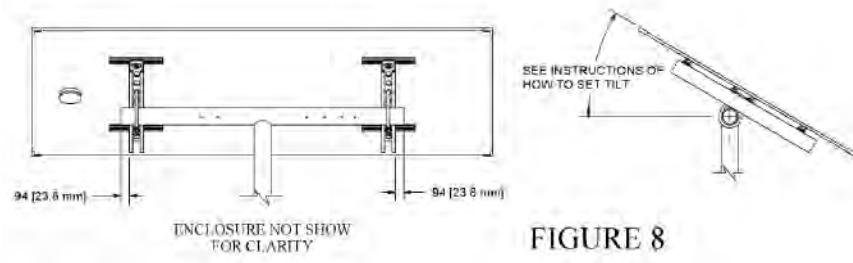
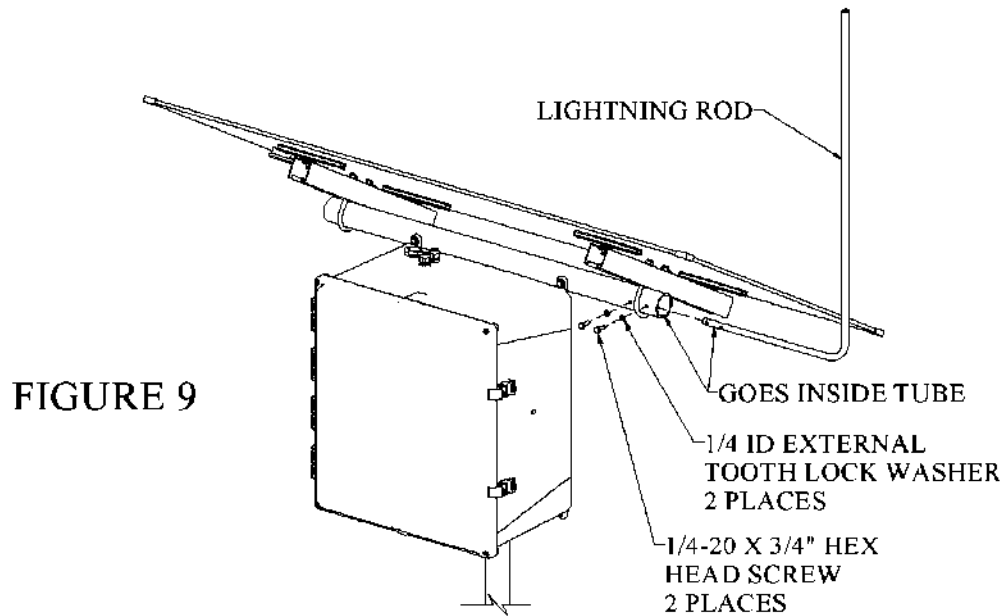

FIGURE 7A
4 PLACES

19. Loosen the locknuts on the two U-Bolts. (See Figure 8) so that the Solar Panel is free to rotate; adjust the panel per the instructions. Use an Angle finder to verify that the tilt angle is correct. For applications outside of the USA and Europe or in the southern hemisphere, contact Hydro BioScience, LLC. **Refer to the section in the manual titled ‘Setting the Tilt of the Solar Panel’.**
20. Tighten the locknuts on the two U-Bolts until Solar Panel is held firmly in place.



21. Install the Lightning Rod as shown in Figure 9. The Lightning Rod is an extremely important component and will aid in diverting a lightning strike away from the electronics by allowing the electricity to flow through the pole and down to the in-ground installed lightning rod.



22. Install Batteries in Enclosure as shown in Figure 10.

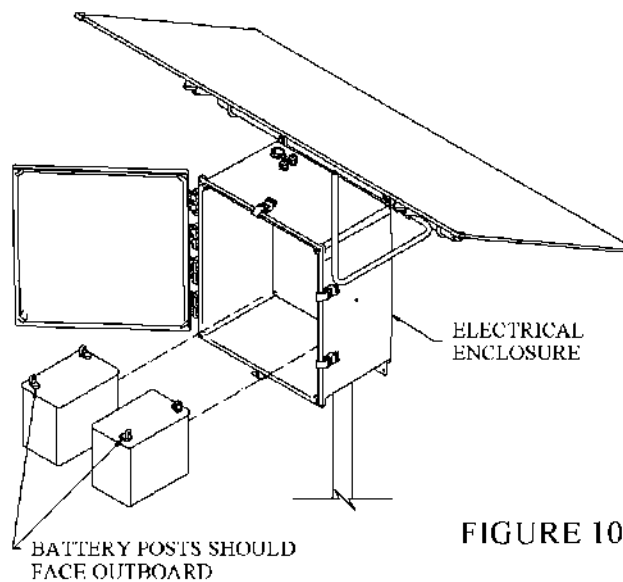

23. Each Battery has a pig-tail wire harness. Connect each battery pig-tail to the Electronic Control Box wire harness mating connector. Also, refer to Figure 11 wiring diagram. Then, connect the output of the Solar Panel to the wires tied to the top of

the 'T' bar. They are polarized and can only mate one way. These two wires run into the Electronic Control Box and affix to TB1(1) and TB1(4).

24. Connect your device to TB1 as shown in Figure 11, where it is designated 'User Load 1'. Connect the Red Positive Wire to User Load 1 '+' (TB1-5) and the Black Negative Wire to User Load 1 '-' (TB1-6). **Note: ensure that the rating of your 'device' matches the electrical rating of the Solar Panel System – for example, if the Solar Panel System's rating is '24Vdc, ensure that your device can accept an input of 24Vdc Battery Voltage Input.**

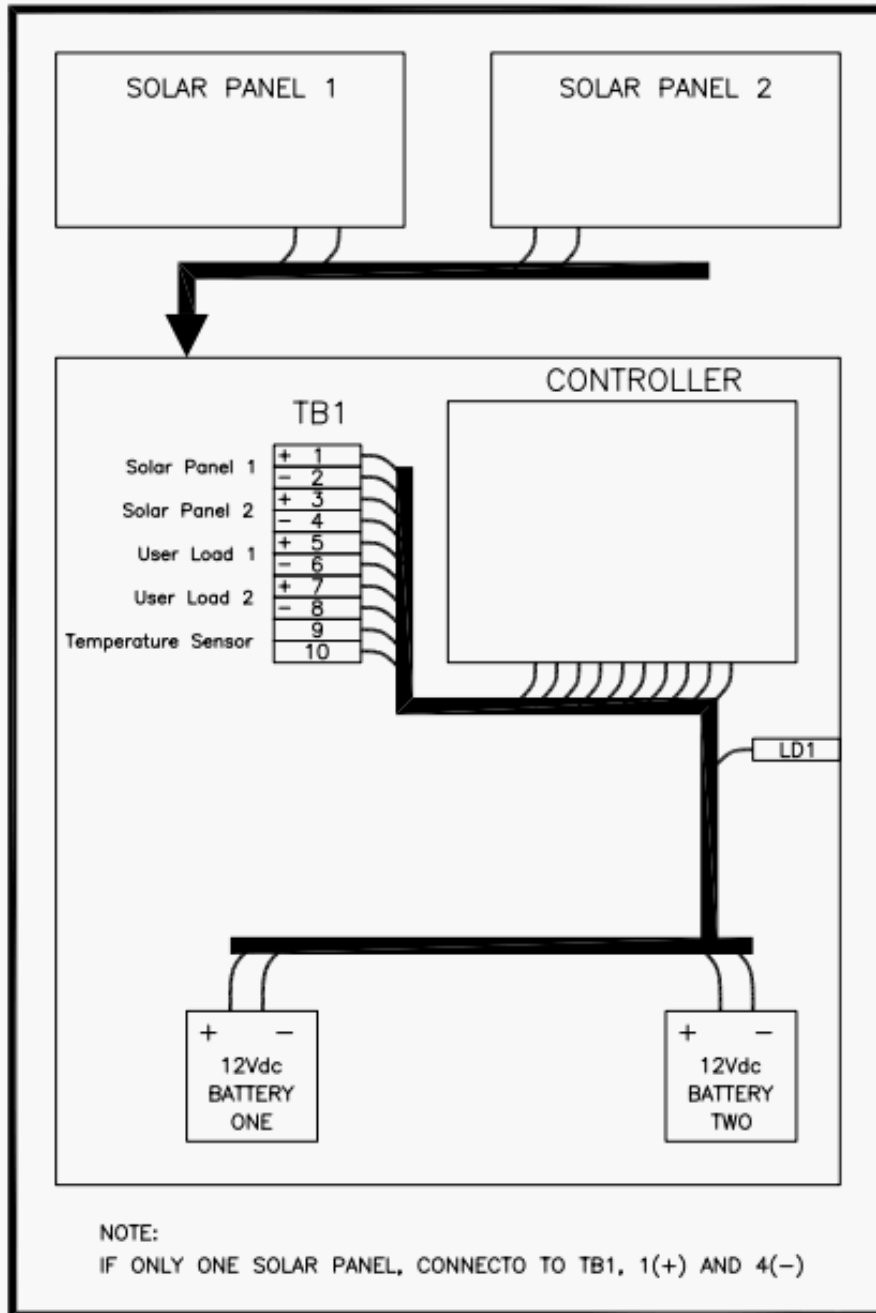

Figure 11

FUSE PROTECTION NOTES: TB1(1), TB1(5), AND TB1(7) HAVE AN INSERT FUSE HOLDER. The fuse holder inserts are not initially installed, but are found in the plastic bag, taped to the inside of the Enclosure Door. Do not install these fuse holders until ready to perform the Commissioning Check List.

Setting The Tilt Of The Solar Panel

25. To get the most power from your solar panel the angle from horizontal, or tilt of the panel, must be set correctly. The tilt should be equal to your latitude, minus 15 degrees in summer or plus 15 degrees in winter. Refer to Figure 12.

Example: If the Solar Panel is located near Oklahoma City which has a latitude of 35 degrees, then:

- 35 minus 15 equals 20 degrees for the summer.
- 35 plus 15 degrees equals 50 degrees for the winter.
- Refer to Figure 13. Using a construction grade protractor, adjust the panel to the calculated degree.

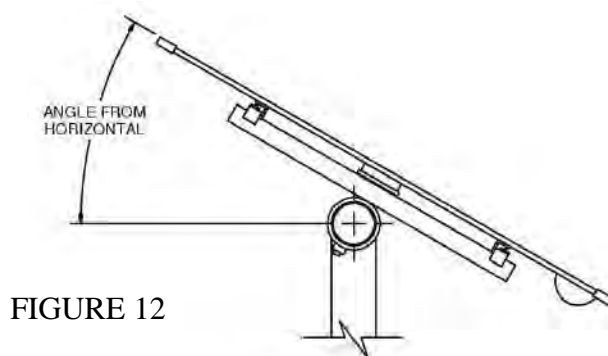
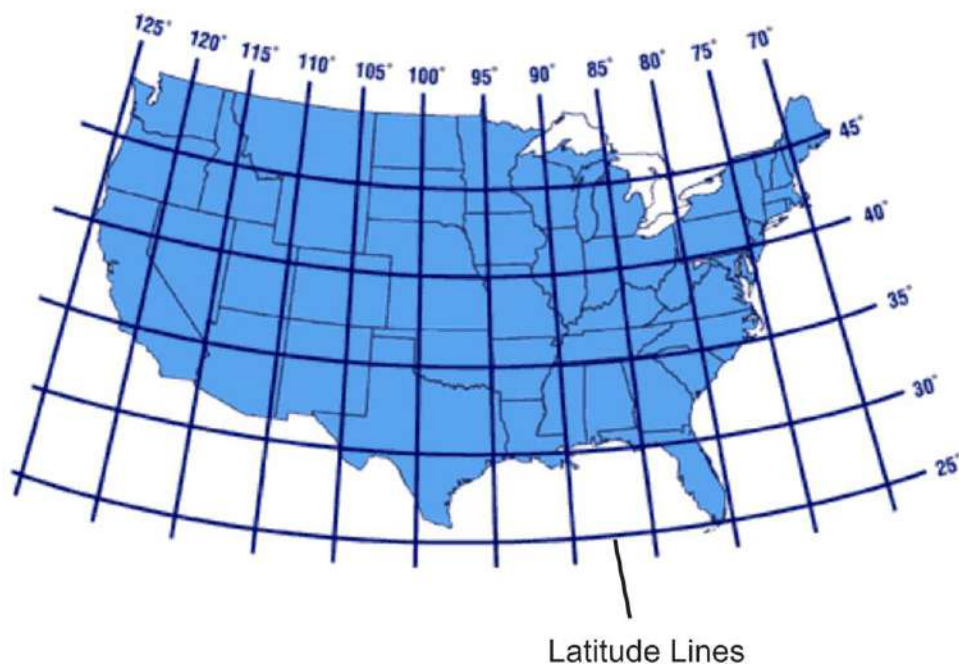

Charger Controller Operations

The Charger Controller is a microprocessor based controller that provides the following functions:

- 5 L.E.D. Display
- 5-stage Matched Charge Algorithm
- Solar Panel Under Voltage Lock-Out
- Reverse Battery Protection
- Low Battery Detect - Electronic shutdown
- Electronic Load Connect/Disconnect Circuit
- Mode Select for selecting one of 8 different Battery Types
- Mode Select for selecting one of 8 different Solar Panel Configurations
- LCD Display Upgrade

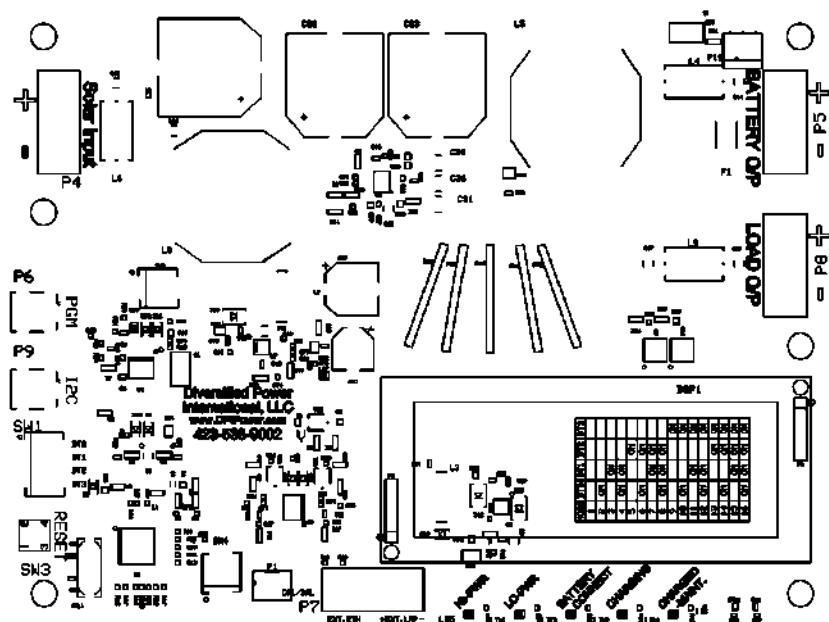

L.E.D. Operation (LD1 to LD5):

Under normal circumstances, the L.E.D.s will illuminate continuously, be off, or flash in a regular pattern. However, if any L.E.D. flashes in a pattern of 'On-On-On-Off' This is an Error Code. The charger shut down and is indicating a one of 16 possible errors – refer to the Error Code Section to decode the error and fix the problem.

Normal LED Operation:

- LD5 Red Illuminates when Solar Panel input power is greater than 50% of rating.
- LD4 Red Illuminates when Solar Panel input power is less than 50% of rating
- LD3 Red Illuminates when Battery is not connected, or overall battery voltage is less than 8Vdc. Normally, when battery is healthy and connected, this L.E.D. should be off.
- LD2 Yel Flashing at a steady rhythm : Controller is testing the battery pack
On continuously when charging at full output rating of controller
- LD1 Grn On continuously when battery fully charged. Controller will then maintain battery at full charge for the remainder of the day.

Basic Operation:

1. When batteries are first connected to the system, the Controller will not react. Upon Connection of the solar panel to the system, the Controller will react by flashing Charge Mode Setup Code L.E.D.s, during the first 3 seconds of power up. There are 8 Charge Modes as follows:

2. The Charge Mode is annunciated as follows (L.E.D.s will Flash). Also, on the PCB, SW1 selects the Mode:
 - Mode-1: LD1 Used for 26AH or less Deep Cycle Batteries
 - Mode-2: LD2 Used for 30 to 44AH Deep Cycle Batteries
 - Mode-3: LD1, LD2 Used for 44 to 50AH Deep Cycle Batteries
 - Mode-4: LD3 Used for 50 to 80AH Deep Cycle Batteries
 - Mode-5: LD3, LD1 Used for 80AH to 150AH Deep Cycle Batteries
 - Mode-6-8, Reserved At time of print, these modes will default to using Mode-2 values
3. After annunciating the mode, the controller enters the first Charge Stage and checks the battery. LD2 will flash for approximately 10 seconds. If the battery was severely discharged, this charge stage may last longer (1-2hrs).
4. Constant Current Stage is entered (LD2 on continuously), where the controller will charge the battery at the maximum available power it has available from the panel, up to its rated output and charging will continue throughout the next 4 stages, until charge is complete.
5. LD1 will illuminate continuously when charge is complete, and during this stage, the controller will only maintain the battery at full charge throughout the day.
6. LD5 and LD4 help to give an indication about the power available from the panel. If LD5 is illuminated, it means that the panel is receiving full sun and delivering its maximum potential. When LD4 illuminates, it means that the panel is delivering less than 50% of its potential power. Under this circumstance, power has been marginalized due to:
 - Cloud or weather conditions
 - Low horizon sun
 - Dirty panel – clean panel thoroughly
 - Loose wire connections – re-check all wire connections from Panel to TB1
7. LD3 illuminates only when the controller has enough input power, but the battery has not been detected. Check Battery voltage and that it is above 8Vdc and that a battery is in fact connected – re-check all wire connections and the connectors themselves. It is not uncommon for the pins inside the connector to ‘slip out of place’.
8. In the event that a charge or system fault should occur, the controller, using LD5 to LD2, flashes at an ‘ON-ON-ON-OFF’ pattern.

<u>Fault Description</u>	<u>LD5</u>	<u>LD4</u>	<u>LD3</u>	<u>LD2</u>
Wrong Battery Voltage	OFF	OFF	OFF	FLASH
Reverse Battery	OFF	OFF	FLASH	OFF
User Load – OverLoad	OFF	OFF	FLASH	FLASH
Battery Thermal Runaway 1	OFF	FLASH	OFF	OFF
Battery Thermal Runaway 2	OFF	FLASH	OFF	FLASH
Charge Time-Out 1	OFF	FLASH	FLASH	OFF
Charge Time-Out 2	OFF	FLASH	FLASH	FLASH
User Load – Over Discharge	FLASH	OFF	OFF	OFF
Battery Test Error 1	FLASH	OFF	OFF	FLASH
Battery Test Error 2	FLASH	OFF	FLASH	OFF
Battery Test Error 3	FLASH	OFF	FLASH	FLASH
Battery Over Temperature	FLASH	FLASH	OFF	OFF

The above listed Fault Descriptions will be covered in the section ‘Troubleshooting’.

External L.E.D. Light-Flash Fault Indicator

In the event that the Controller must disconnect the load AND also disconnect itself from the system to prevent excessive battery drain, a separate circuit will flash the high intensity L.E.D. for an additional amount of time of time of approximately 4-8hrs, to alert someone about requiring service. This L.E.D. circuit is highly efficient and uses minimal power. The External L.E.D. operates from the P7 Terminal Connection on the PCB.

Troubleshooting

In the event of a System Failure, as indicated by an Error Code displayed on the L.E.D.s or other symptoms, please review the following items to try to correct the condition before calling Customer Service.

Error Code Related Check List:

Wrong Battery Voltage	Check the battery type installed. The charger is rated at 24Vdc and may be trying to tell you that the battery pack is a 12v or 36v or other type of battery.
Reverse Battery	Recheck connections to battery and ensure that a reverse connection OR short circuit of the Battery Leads does not exist.
User Load – OverLoad	Recheck Load connections and check for short circuits, or extremely heavy loads such as motors, etc, that far exceed the rating of the charger.
Battery Thermal Runaway	One of two error codes – Runaway 1 or 2, may indicate the batteries need to be replaced. As batteries age, the charge profile has changed and the charger picked up a signature that may indicate the batteries are out of balance.
Charge Time-Out	One of 2 error codes – Time-Out 1 and 2 indicate that the batteries did not reach a state of charge within a same amount of charge time – check that the batteries installed do not exceed the AH Capacity rating of the Mode selected by P2,3,4,5.
User Load – Over Discharge	The User Load has over-discharged the battery pack, and the controller had to disconnect the load from the battery to prevent permanent battery damage. This may caused by: <ul style="list-style-type: none">• Lack of sunpower extending longer than 5 days• Dirty panels and/or shadows cast upon panels – even temporarily• Load drawing more power than designed for• Loss of Battery Capacity – check battery capacity using Load Tester
Battery Test Error	Test Errors 1,2,3 all indicate a battery pack that may need to be replaced. Try using an external charger – with a matched algorithm, available from Customer Service, to re-charge battery fully, before putting back into service.
Battery Over Temperature	Only occurs if a thermistor, connected to the battery, has signaled a battery condition that indicates the battery is too hot. Currently, temperature sensors are not used.

Other Trouble Shooting Check List Items:

Battery Replacement	All lead-acid batteries differ from one make to the next and from one manufacturer to the next. It is extremely important, that when working with batteries, the following rules are follow: <ul style="list-style-type: none">• In any series configuration of 2 or more batteries in the battery pack, and when changing one of the batteries, always change ALL of the batteries to ensure that the batteries are all the same Age, Type, Rating, Condition, Charge Level. Failure to follow this rule may result in an unbalanced battery pack and cause property damage and/or bodily injury.• Use only approved battery types in the system – available by calling Customer Service. The metal alloy, used in the battery construction, differs from one battery to the next, resulting in different charge requirements.
----------------------------	---

Maintenance

To ensure proper operation, and receive maximum benefit, a small amount of maintenance is required. Some items must be scheduled.

1. Solar Panel must never be under a shadow. Remove all shadow causing obstructions. Even if a shadow is caused temporarily every day, this will significantly reduce system capability.
2. Inspect Solar panel for debris, bird feces or dust on a once daily schedule and clean with soap and water or a glass cleaner.
3. Inspect system monthly for:
 - 3.1. Any loosening of nuts/screws and tighten if needed.
 - 3.2. Any loosening of strain reliefs and fittings and tighten if needed.



Once Every 2 Months – check tightness of lightning rod bolts, that secure the lightning rod to the top of the ‘T’ structure (x2), and ensure that lightning rod is secure.

Preparing for Winter Storage

Prepare for Winter Storage when mean day to day high temperatures begin to average below 10°C (50°F).

Open the door of the Grey Electrical Enclosure. Unplug both batteries from the wire harness and remove from the box. Close door.

Store the batteries inside a room that can be maintained at a temperature of 10°C (50°F) minimum. The batteries must NOT be stored on a concrete floor – instead, place on a wood board or other non-concrete material floor.

Use a charge maintainer type charger to keep batteries fully charged while in storage. Lead Acid Batteries lose 20%-40% of their charge per month. During a 3 month storage period, and without the use of a maintainer, the batteries may become over discharged and over-sulphated, dramatically reducing their performance for the next season and voiding the battery warranty. Contact our Customer Service department by calling the number, found on the last page of this document, and inquire about our 10-channel charge maintainer. This maintainer has a matched charge algorithm to your Deep Cycle battery and one single charge maintainer will maintain 10 batteries at once.

Retrieving from Winter Storage

- **Prepare to setup for the season, after winter when mean day to day high temperatures begin to average above 10°C (50°F). Retrieve batteries from Winter Storage Room by disconnecting them from the charge maintainer.**
- Allow batteries to sit unconnected from charge maintainer for 1hr. After the 1hr period, verify battery voltage, by measuring with a voltmeter, and confirm that the battery voltage is above 12.5Vdc.
- Install batteries back into Electronic Control Box and connect Battery wire harness connector back to the Wire Harness.
- Confirm that the batteries are charging – Refer to the Operations Section Dealing with the Systems Controller.

Commissioning Check List



Prior to commissioning the system into service, use the following check list to review construction and setup.

1. MECHANICAL INSPECTION

- a. FRAME
 - i. Alignment of Frame to True South in accordance with Appendix-A instructions.
 - ii. Frame Base Plate Secured to Concrete.
 - iii. L-bolt nuts secured and thread locked with Loctite #2440.
 - iv. Bubble Wrap Protection removed from Vertical Bar of Frame.
- b. IN-GROUND AND FRAME MOUNTED RODS
 - i. Ensure Ground Wire Connection to the L-Bolt and Nut fastener and also the Ground Lug Connector connecting the wire to the Grounding Rod has been saturated in Spray Paint.
 - ii. In-ground lightning rod secured to copper wire via Ground Bolt.
 - iii. Other end of copper wire secured to L-bolt and Frame Base Plate.
 - iv. Nuts, securing Lightning Rod on T-Frame, secured and thread locked using Loctite #2440.
- c. GREY ELECTRONICS ENCLOSURE
 - i. Mounting Fasteners tight.
 - ii. Wire Strain Relief Through-Holes secured.
 - iii. After using Instruction Manual, place manual in pocket located inside of enclosure door.
- d. SOLAR PANEL ARRAY
 - i. Nuts on U-Bolts secured tight and thread locked with Loctite #2440.
 - ii. Tilt Angle Adjusted from Horizontal: Record Tilt Angle here: _____
 - iii. Panel Wire Connectors fully secured to mating connector wires.

2. ELECTRICAL INSPECTION

- a. SOLAR PANEL ARRAY
 - i. Using a digital Voltmeter set to 'DCV', check the following points:
 1. TB1(1) and TB1(4) - Verify measurement of greater than 40Vdc, with sun present.
 2. Each Battery Voltage should read greater than 12.2Vdc.
 3. TB1 User Load Terminals – each should read greater than 24Vdc.
 - ii. TB1 wire connections – check all to ensure that they are secured.
- b. GREY ELECTRICAL ENCLOSURE
 - i. Locate Bag of Fuse Holders, taped to the inside of the Grey Electrical Enclosure Door, and install into TB1(1), TB1(5) and TB1(7).
 - ii. Charge Controller charging (L.E.D. activity noted).
 - iii. Using Digital Voltmeter across battery pack, verify battery voltage is increasing, or measuring above 28Vdc. This may require 2-3 minutes of visual inspection.

APPENDIX-A – Finding True South

Find TRUE SOUTH by following these instructions. True North (the opposite of True South) is never indicated by a compasses needle which actually points to Magnetic North. Refer to Chart-1, and Figures 14 and 15. **NOTE: These instructions are used for locations north of the Equator in North America. Call customer service for instructions needed for installations South of the equator and/or other continents.**

1. Use only a high quality compass and avoid using compass near any metal objects. The compass is not supplied with the Solar Panel Kit.
2. Use Chart-1 to determine your Declination or go to www.ngdc.noaa.gov/geomagmodels/declination.jsp and type in your zip or postal code. Either way you will derive a 'Value of Declination'.
3. Add or subtract the value of declination to the compass's needle angle and you will have found True South.

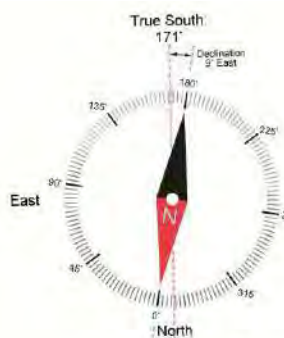

Example 1

Figure 14



Example 2

Figure 15

Example 1: Location Santa Fe, New Mexico. From Chart-1, Value of Declination is approximately 9 degrees east. Subtract from compass reading – Refer to Figure 14.

Example 2: Location Portland, Maine. From Chart-1, Value of Declination is approximately 16 degrees west. Add to the compass reading – Refer to Figure 15.

Magnetic Declination for the U.S.
2004

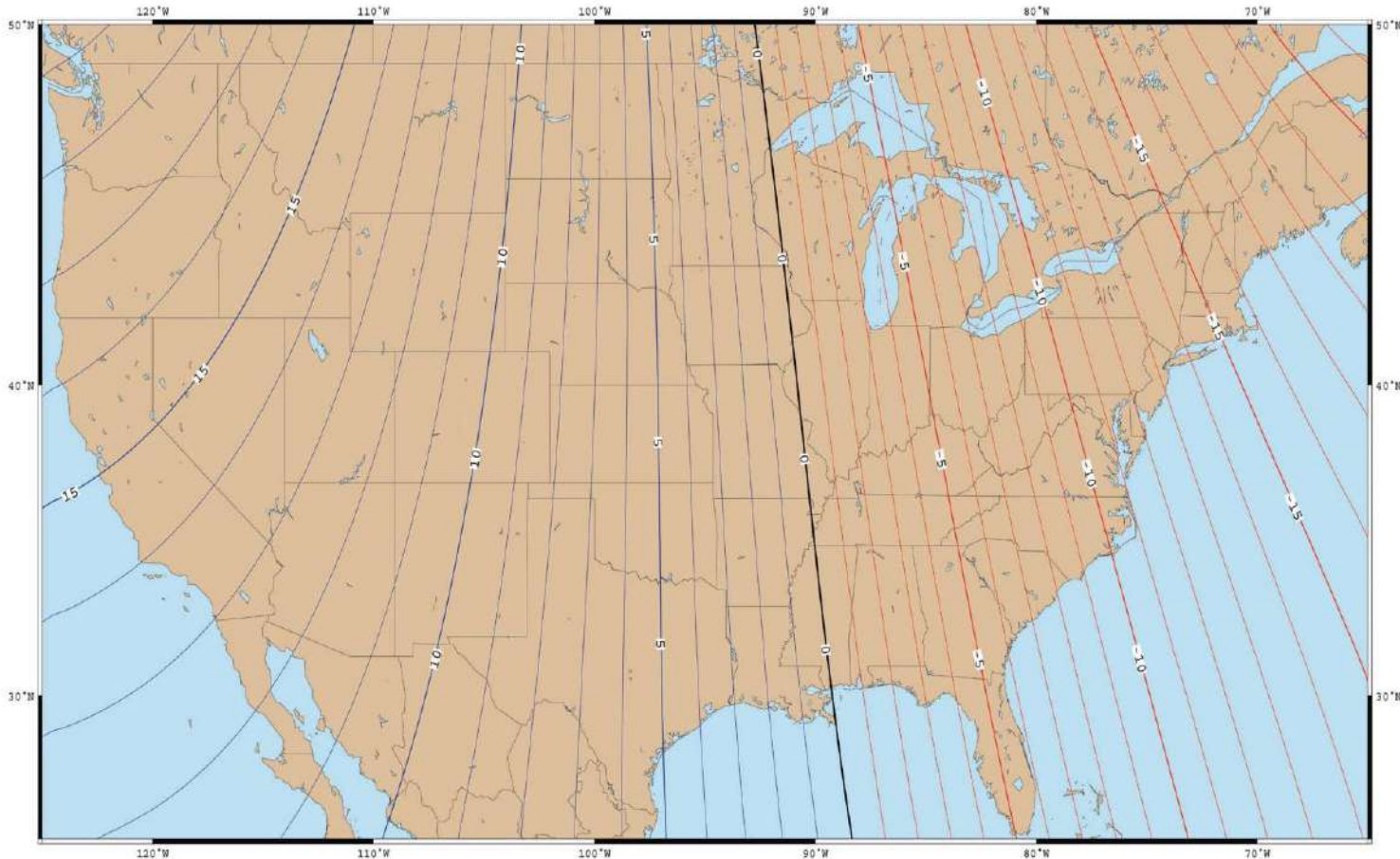

Warranty

Hydro BioScience, LLC (HBS) warrants exclusively to the original purchaser that this product will be replaced or repaired, at HBS's option, if it fails during the first TWO(2) years after date of purchase due to defect in material or workmanship. Proof of purchase is required for all claims. Return product prepaid to:

Hydro BioScience, LLC
414 Century Court
Piney Flats, TN 37686, USA

This warranty does not cover failures arising out of improper use, maintenance or operation of the product, nor failures arising from damage caused by adverse weather conditions such as lightning, flooding, major force winds, etc. Repair or replacement as provided under this warranty is the exclusive remedy of the consumer. HBS shall not be liable for any incidental or consequential damages for breach of any expressed or implied warranty on this product. Except to the extent provided by applicable law, any implied warranty of merchantability or fitness for a particular purpose on this product is limited in duration to the duration of this warranty. Some states do not allow the exclusion of limitation of incidental or consequential damages, or allow limitations on how long an implied warranty lasts, so the above limitations or exclusions may not apply to you. This limited warranty gives you specific legal rights and you may also have other rights which vary from state to state.

Contact Information

HYDRO BIOSCIENCE, LLC
888-500-5011
www.hydro-bioscience.com