



HYDRO BIOSCIENCE[®]
Eco Driven Solutions[®]

40SP-15V60-150 Series
SolaRaft-QDB™, SolaRaft-iQDB™ and SolaRaft-iQDM™
Algae Remediation and Water Quality Monitoring
Dual Float Pontoon Systems



General Product Specifications

Model Number	Description
40SP-15V60A150Y01	SolaRaft without Sonic Heads, probes, or telemetry
40SP-15V60M150Y01	SolaRaft with telemetry, without Sonic Heads or probes
40SP-15V60A150Y02	SolaRaft-QDB with Single Quattro
40SP-15V60A150Y03	SolaRaft-QDB with Single Mezzo
40SP-15V60A150Y04	SolaRaft-QDB with Dual Quattro
40SP-15V60A150Y05	SolaRaft-QDB with Dual Mezzo
40SP-15V60A150Y06	SolaRaft-QDB with Quattro/Mezzo Combo
'A'	Telemetry/Communications package. Change to 'M' to add telemetry
'Y'	Color option. Y-Yellow or B-Black are standard colors



For direct access to the latest copy of this manual,
please scan this QR Code or refer to the *Product*
Manuals section at:
www.Hydro-Bioscience.com

Table of Contents

























1. <i>Safety Information</i>	3
SAFETY SYMBOLS AND TERMS	3
Safety Symbols	3
Safety Terms.....	3
GENERAL SAFETY REQUIREMENTS	4
User Safety and General Product Precautions.....	4
Uses	5
Limitations and Disclaimers	5
2. <i>Installation</i>	6
PRODUCT FEATURES	6
UNPACKING AND FIRST TIME DEPLOYMENT	8
ANCHOR AND SONIC HEAD PLACEMENT	10
Anchoring the Algae Remediation System.....	11
SONIC HEAD CABLE CONNECTION	11
Single/First Sonic Head Installation.....	11
Sonic Head with ForteConn™ Power Connector.....	11
Sonic Head with Cable Splice Connector.....	12
Connecting to SolaRaft and Solar Controller.....	15
Dual/Second Sonic Head Installation	15
STEVEN'S WATER TELEMTRY/MODUM	17
SONDE PROBE	18
Eureka SONDE Probe Installation.....	18
3. <i>Operation</i>	19
HOW TO OPERATE SONIC HEADS	19
Solar Powered Systems	19
WHAT TO EXPECT AFTER INSTALLATION	19
SONIC HEAD MAINTENANCE	20
4. <i>Appendix</i>	21
SOLARAFT STORAGE AND RE-DEPLOYMENT	21
Storage	21
Redeployment	22
TYPICAL SOLARAFT CIRCUIT CONNECTION	22
AFFECTED ALGAE SPECIES*	23
Typical Area Coverage:.....	23
PRODUCT DIMENSIONS	23
5. <i>General Warranty</i>	24

1. Safety Information

SAFETY SYMBOLS AND TERMS

Safety Symbols

The following symbols may appear on the product:

	Direct current (DC)		Caution, risk of danger
	Alternating current (AC)		Warning, risk of electric shock
	Both direct & alternating current		Risk of explosion
	Ground terminal		Recycle lithium-ion batteries
	Chassis ground		Do not incinerate
	Power on/off		Power port
	Battery/cell power connection		Battery/cell power connection
	Communication port		Solar panel port
	Repair/service		AC connection port
	Navigation light connection		MyQuattro App communication
	Conforms to European Union directives		
	Complies to the Federal Communications Commission		
	Complies with the Restriction of Hazardous Substances Directive (2002/95/EC)		
	This product complies with the WEEE Directive (2002/96/EC) marking equipment. The affixed product label indicates that you must not discard this electrical/electronic product in domestic household waste.		

Safety Terms

Terms in this manual:

-  Warning/Caution: 'BE ALERT – YOUR SAFETY IS INVOLVED'. If you do not follow these safety instructions, personal injury, loss of life, and/or property damage may occur.

Terms on the product:

Danger: Indicates an immediate hazard which will result in death or serious injury.

Warning: Indicates a hazard which may result in death or serious injury.

Caution: Indicates a hazard which may result in minor or moderate injury.

GENERAL SAFETY REQUIREMENTS

 **WARNING - Read this manual thoroughly before using the battery.**

User Safety and General Product Precautions

1. Locate/route all cords where they will not be tripped over or damaged by vehicles or equipment with cutting blades such as lawn mowers and hedge clippers and away from vehicle/boat traffic to prevent being driven over.
2. When deploying, follow all equipment and vehicle (such as boats, rafts) operator safety manual instructions.



3. Installation and working in and around water always requires 2 or more individuals for safety.
4. If wildlife such as beavers, minks, nutria, otters, muskrats, turtles, etc., are present in the water body, additional cable protection is recommended such as a nylon or polyester braided sheath from the surface down to about 2 meters (6 feet) depth.
5. Other manuals included with this manual, such as battery, solar controller/charger, Sonic Head, and SolaRaft manuals must be read fully. Comply with all safety precautions in those manuals. This manual contains only assembly excerpts from these other manuals. **Visit our website www.hydro-bioscience.com to locate these manuals. Alternately, download the manuals by scanning the QR code shown on the white label located on the inner wall of the side panel.**
6. Personal Precautions While Working with Batteries:
 - a. Have someone within range of your voice to come to your aid if needed.
 - b. Have plenty of fresh water and soap nearby in case battery acid contacts your skin, clothing, or eyes. Wear eye and clothing protection and avoid touching your eyes.
 - c. If battery acid contacts skin or clothing, wash immediately with soap and water.
 - d. If acid enters your eye, immediately flush the eye with running cold water for at least 10 minutes. Get medical attention immediately.
 - e. NEVER smoke or allow a spark or flame in the vicinity of a battery.
 - f. Be extra cautious not to drop a metal tool onto a battery. It might spark or short circuit the battery or other electrical part that may cause an explosion.



- g. Remove personal metal items such as rings, necklaces, watches, etc. Batteries can produce a short-circuit current high enough to weld such items causing a severe burn.
 - h. NEVER charge a frozen battery. Thaw it out for safer and more efficient charging.
 - i. **WARNING: For your own protection, when using ANY type of charger, always ensure that the batteries in your Battery Pack ARE ALL at the same state of charge, same condition, same size, and same rating. DO NOT MIX DIFFERING BATTERY SIZES, BATTERY TYPES OR OLD BATTERIES WITH NEW. Never use a charger for any purpose contrary to its intended purpose of charging rechargeable batteries in accordance with ALL instructions printed in the Charger's manual.**
7. Personal Precautions While Working with Solar Panels:
- a. Follow all safety precautions recommended by the solar panel supplier including safe installation practices.
 - b. Solar Panels can generate high voltages greater than 43.2Vdc.
 - c. Necessary precautions include:
 - I. Avoid short circuits which can produce energy arcing which can cause severe burns and/or property damage.
 - II. Avoid touching bare wires which can cause personal harm, and even death – DC currents can be lethal.
 - III. Use a minimum of one-gauge larger conductor than the appropriate rated wire for solar panel's Short Circuit Ampacity rating.

Uses

The HBS Algae Remediation Products treat bodies of water such as lakes, ponds, etc. as an aid in preventing, reducing, and in many cases eradicating harmful algal blooms.

Limitations and Disclaimers

Due to environmental and manmade conditions contributing to excessive nutrient loading and many other factors, varying degrees of product efficacy should be expected and therefore, there is no guarantee regarding the total prevention or eradication of algae or algal blooms. HBS Algae Remediation products do not treat any body of water to produce potable or drinkable water. HBS Algae Remediation Products do not treat for other bacterium, pollution, viruses, toxins, micro-organisms, or other matter which may be present, and other methods of treatment may be needed to provide prevention, remediation, or elimination of such. HBS Algae Remediation Products are not a replacement for other water treatment methods, including, but not limited to, aeration, chlorination, oxidation, skimming, or other treatments meant to prevent, reduce, or eliminate other bacterium, pollution, viruses, toxins, micro-organisms, or other matter which may be present. HBS Algae Remediation Products are not to be utilized for off-label or unintended uses. Such off-label or unintended use may void the product's warranty and/or cause damage to persons or property.

2. Installation

PRODUCT FEATURES

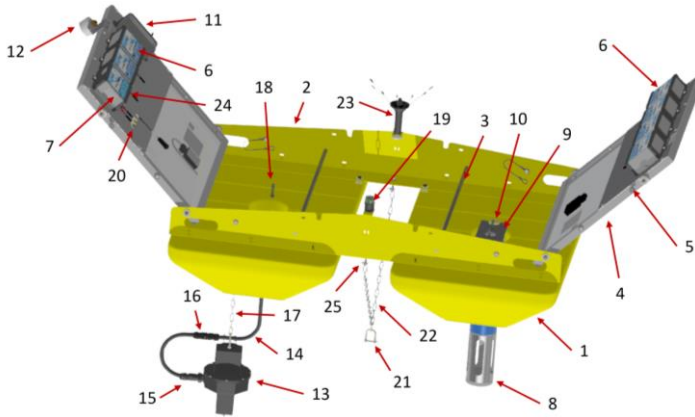

1. Float (x2): Combined buoyancy is approximately 108kg (240lbs).
2. Side Panel Frame (x2): Stabilizes solar panels and buoys.
3. Lateral Stabilizing Bar (x2): Do not suspend objects, nor use them to support anchors, sonic head attachments, nor SONDE probes.
4. Solar Panels (x2): Develop more than enough energy to power two Algae Remediation Sonic Heads (13) and SONDE probe (8), while charging battery packs (6).
5. Solar Panel Lock Screws (x4): Keeps solar panels (4) locked in place in the Side Panel Frame (2).
6. Battery Packs (x6): Two battery packs mounted on one solar panel and four mounted on the other panel. Battery packs are waterproof and rated at IP68. Refer to instruction manual located at www.hydro-bioscience.com.
7. MPPT Solar Controller: Takes in solar power and charges battery packs, controls power to Sonic Heads via Channels One and Two, drives flashing of NAV light, and communicates via Bluetooth and serial communications. Solar Controller is waterproof and rated at IP68. Refer to instruction manual located at www.hydro-bioscience.com. A MyQuattro™ App is available free for use on Android smartphones to communicate via the Bluetooth connection.
8. SONDE Probe: Measures water quality metrics and transfers measurements to telemetry/modem module (11) or Solar Controller via its channel three connection. This probe, along with items (9) and (10) are optional and purchased separately.

9. SONDE Probe Mounting Plate: Via this plate, or for other suspension methods, a SONDE probe can be mounted. (Purchased Separately)
10. SONDE Probe Mounting Plate Thumb Screws (x2): Use two thumb screws to secure the SONDE plate. Alternately, an eyebolt threaded into one of the thread holes, included with the extra parts kit, can be used in combination with a rope or chain, to suspend the SONDE unit. The SONDE Probe is meant to slide down into the hole of the Float (1) and secure in place to the mounting plate (9) or eyebolt. (Purchased Separately)
11. Telemetry/Modem Module: Optional and purchased separately. Refer to its instruction manual located at www.hydro-bioscience.com. The modem communicates with the Solar Controller via its POWER/COMMS Port. It has three ports to provide a connection to a SONDE Probe (8), or other serial devices via its additional ports Two to Four. The modem communicates with the cloud to provide cloud-based monitoring services and GPS position coordinates.
12. Telemetry/Modem Antenna: Communicates with GPS and Cellular.
13. Algae Remediation Sonic Head
14. Algae Remediation Sonic Head Power and Communications Cable
15. ForteConn™ Power Connector
16. Cable Splice Connector
17. Algae Remediation Sonic Head Suspension Chain
18. Eyebolt and Carabiner Clip: Used to connect and secure Algae Remediation Sonic Head Suspension Chain (17) to the Float (1).
19. NAV Light (navigation and warning light)
20. Strain Relief P-Clamps (x2) and Thumb Screws (x2): Provides strain relief between Solar Controller (7) and Sonic Head (13).
21. D-Shackle: Used to connect the SolaRaft to the customer supplied anchor system.
22. Anchor Chain: Used to connect the SolaRaft to the customer supplied anchor system to prevent the SolaRaft from floating away.
23. Bird Deflector: Wire array assembly that deters birds from resting on the solar panels.

24. LOCKOUT: When plugged into the 'COMMS' port on the Solar Controller (7), the SolaRaft is powered down for shipping or storage.
25. Alternate hanging option for Algae Remediation Sonic Head

UNPACKING AND FIRST TIME DEPLOYMENT

Refer to [PRODUCT FEATURES](#) figure and related call-out numbers. The call-out numbers are referenced below in parenthesis.

A photographic step-by-step manual is also available.

Using a two-person team, remove product from its packaging and rest it on a flat surface. Follow these steps to deploy the SolaRaft:

1. Depending on the length of time the product may have spent in a warehouse, the product may have to sit in the presence of sunlight for 24 hours to charge the batteries prior to moving ahead with the steps below. This first step may be skipped if the product has not sat in storage longer than 6 months. If the batteries need charging, perform steps 2 and 5 then swing the solar panels to the closed position and install the four Solar Panel Lock Screws (5). After the batteries are charged, proceed with step 2.
2. Locate and remove the four Solar Panel Lock Screws (5). Carefully swing open the two solar panels (4) fully, until the lanyards support the open solar panels. Do not allow the solar panels to drop open.
3. Remove the protective wrap from the Sonic Head (13), Chain (17) and Cable (14) and rest the Sonic Head (13) on the floor beside the SolaRaft. The Sonic Head Chain (17) is already connected to the Eyebolt (18) and ensures that its length carries the weight of the Sonic Head (13) and not the Cable (14).

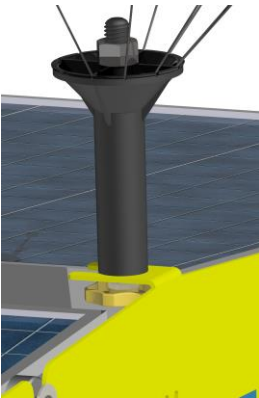

4. Locate the Bird Deflector mounting flange located on the Side Panel Frame (2). Attach the Bird Deflector (23) to the flange hole via its Thumb Screw. Release the Bird Deflector's Wires by removing the two ties from its wires – this may be done after all other steps below are executed to prevent Bird Deflector Wires from getting in the way of other installation steps.

5. Locate the Solar Controller (7). During shipping, the SolaRaft was powered off by one of two methods as mandated by shipping couriers and/or country importation codes. Method One or Method Two are employed as follows:
- Method One: Two wires may not be connected to the Solar Controller (7) – the Solar Panel Positive and Battery Pack Positive. These are identified by the printed heat shrink on the terminals. Plug these two wires into the Solar Controller Tabs.
 - Method Two: Locate Channel Three Output on the Solar Controller (7). This Channel is labeled 'COMMS'. Remove the Plug labeled 'LOCKOUT' (24) from the receptacle.
 - If the Telemetry/Modem Module (11) was purchased and accompanied the product, the same 'COMMS' port is used.
 - In this case the Telemetry plug will be found near the 'COMMS' port. Plug the connector into the 'COMMS' port.
 - The Telemetry/Modem Module installation is found below.
 - The NAV Light (19) will begin to flash.
6. If a Telemetry/Modem Module option was purchased, there are two options:
- Option one: Uses a Steven's Water Telemetry/Modem not shown in the [PRODUCT FEATURES](#) figure. Refer to the section titled "[STEVEN'S WATER TELEMTRY/MODUM](#)" and install.
 - Option two: Uses an HBS Telemetry/Modem (11) option. If the Telemetry/Modem option was purchased with the SolaRaft, then it is already installed. Refer to these steps to complete the installation:
 - Locate the Solar Controller (7) and identify the port labeled 'COMMS'. If the SolaRaft shipped to you, it is a first-time deployment, and the LOCKOUT (24) is plugged into the 'COMMS' port, then remove the LOCKOUT. Locate the modem power cable and plug the connector into the port.
 - Refer to the Telemetry/Modem manual located at www.hydro-bioscience.com for a full list of operating instructions.
7. If a SONDE Probe Option was Purchased, refer to the section titled "[SONDE PROBE](#)" and install the probe's power cable wiring now. Do not install the probe mechanically since its sensor array is delicate and should not hit the floor. After wiring in, lay the probe on its side on top of the Floats (1). After the SolaRaft is floated out to water, mechanically secure it in place to the Float (1) using the bail hanger supplied with the probe. The probe can also



be mounted using its Mounting Plate (9) and Thumb Screws (10). (Purchased Separately)

8. The Anchor Chain (22) and its D-Shackle (21) should be released from the Lateral Bar (3) by removing the D-Shackle pin. Once released, re-install the D-Shackle pin so that it does not get misplaced. Allow the Anchor Chain to fall between the two Floats (1).
9. Swing both Solar Panels (4) back into position and secure the panels with the 4 Solar Panel Lock Screws (5).
10. Move the Solaraft out into the body of water intended to be treated along with an Anchor and a length of Anchor Chain or Anchor Rope and all hardware necessary to construct the anchoring system (all items are supplied by the installer).
 - a. The Anchor, supplied by the installer, should typically weigh anywhere from approximately 9kgs to 23kgs (20lbs to 50lbs) but is also dependent on the environment that surrounds the body of water; for example, consideration to storms, waves, and wind may require a heavier anchor.
 - b. Also refer to the section titled "[ANCHOR AND SONIC HEAD PLACEMENT](#)" for hints at creating the anchor system.

ANCHOR AND SONIC HEAD PLACEMENT

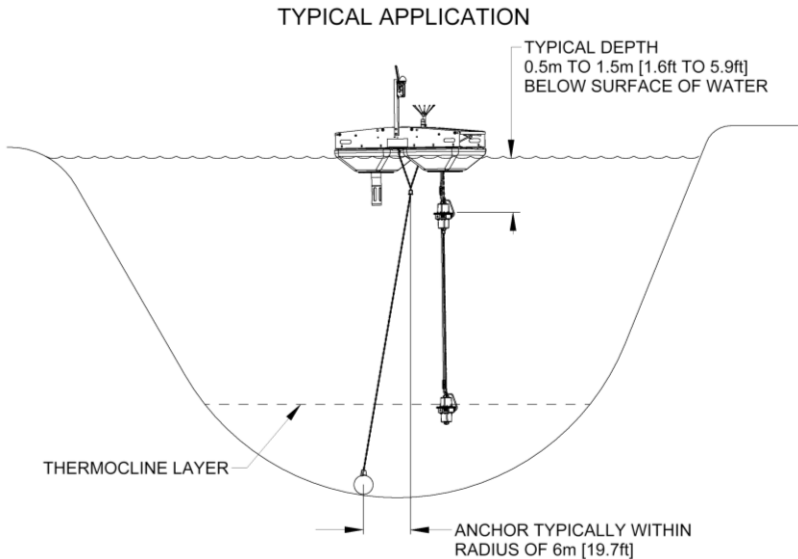

Anchoring the Algae Remediation System

1. A typical 9kgs to 23kgs (20lbs to 50lbs) anchor ball, available from many sources including marinas and retail stores, is needed to keep the SolaRaft in place. The anchor is first tied to a marine grade rope or stainless-steel cable or a chain and dropped until it rests on the lakebed.
2. Alternatively, cinder blocks or other heavy weights can be considered.
3. Attach the other end of the anchor rope or cable or chain to the D-Shackle (21). There must be slack in the anchor rope, cable, or chain so that the SolaRaft can float around the anchor point with a radius of 6m [19.7ft] (see figure above). If there is no slack, a slight increase in water level could dislodge the anchor and allow the SolaRaft to float away.

SONIC HEAD CABLE CONNECTION



If a cable connector is supplied which connects to a power supply, apply a very small 3mm diameter spot or less of dielectric grease to all socket contacts – not pins. This protects from corrosion, moisture, and dirt when connectors are disconnected. Any dielectric grease or lubricant used must conform to NSF-61 Marine Grade standards.

Single/First Sonic Head Installation

Refer to the upper Sonic Head in the figure above.

If the SolaRaft was purchased with a Sonic Head, then it should already be installed. If installing a Sonic Head in a SolaRaft without a Sonic Head, follow the steps below.

Sonic Head with ForteConn™ Power Connector

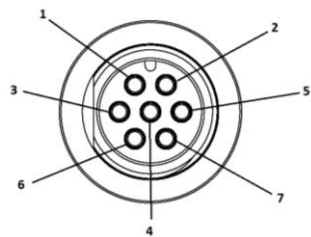

A ForteConn™ power connector, when used on a Sonic Head, has a pin-out described here:

- Circuit-1: RS-485 A Communications
- Circuit-2: RS-485 B Communications
- Circuit-3: Positive(+) Power Input Pin
- Circuit-4: Sonic Head Heartbeat Signal
- Circuit-5: Negative(-) Power Circuit Common
- Circuit-6: Serial Communications
- Circuit-7: Serial Communications

The figure above shows the Sonic Head Connector where the view is from the front side of the connector, looking at the receptacle connector pins.

Securing Cable to Sonic Heads

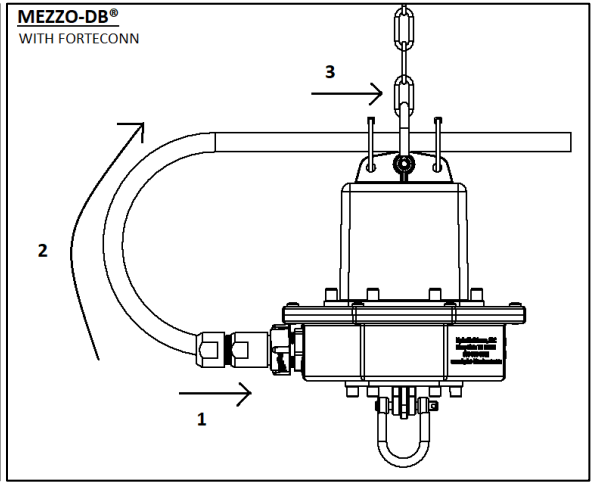
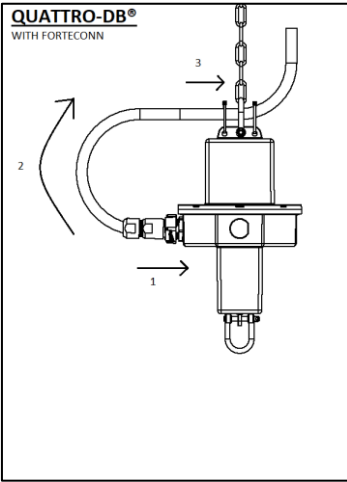

 To avoid a non-warranty claim, follow the installation instructions below.

IMPORTANT

 **NEVER USE THE STRAIN RELIEF LOOP OR THE POWER CONNECTOR AS A HANDLE. ALWAYS USE THE CHAIN ON THE TOP OF THE UNIT WHEN LIFTING THE SONIC HEAD.**

1. Use the supplied cable.
2. Apply 3mm diameter spot of dielectric grease to any contact socket (not pin) to aid in the resilience to moisture dirt and grime.
3. Make a strain relief loop for the Power Cable by making a radial bend and secure it to the top mounting tab holes of the Sonic Head with cable ties (as shown above). Clip off excess cable tie straps with flush cut trimmers or scissors.
4. Use the supplied D clasp to attach chain that connects the Sonic Head to the Solaraft to the top center mounting hole of the Sonic Head.
5. **Always secure the cable to the Sonic Head using cable tie straps to prevent damage to the ForteConn connector.**

Sonic Head with Cable Splice Connector

Applicable on Sonic Heads with a 12in (305mm) cable tether. This connector is an IP68 rated cable splice that can be used in field repair or upgrading to newer sonic heads. This connector may be ordered as a kit – KITM0262. Go to www.Hydro-Bioscience.com to contact the RMA department to place order.

Figure 1

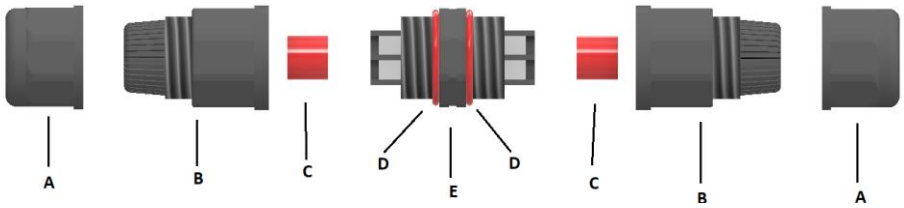
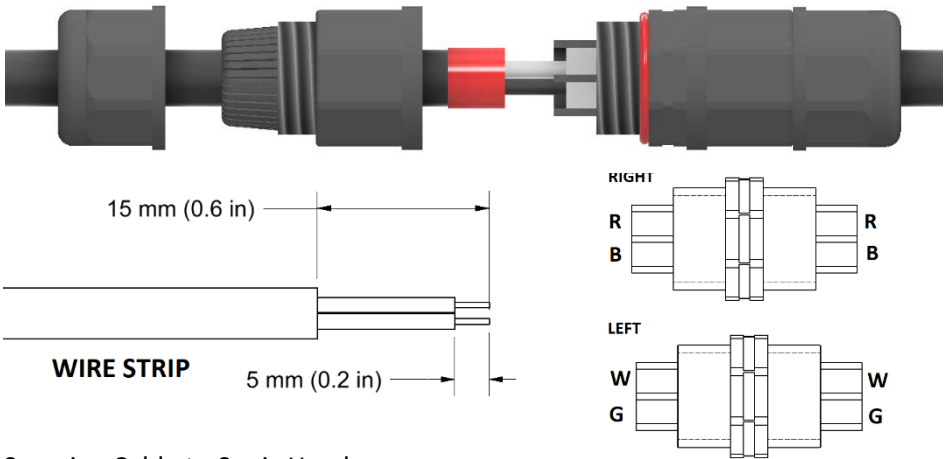

Figure-1 Parts Description

- A. Cable Sealing Cap – one for each side
- B. Connector Housing – one for each side
- C. Cable Sealing Cap Grommet – one for each side
- D. Red O-ring for sealing – one for each side
- E. Connector Splice Terminal – 4 circuit for 4 wires

Figure-2 Connecting Cables to Splice



Securing Cable to Sonic Heads

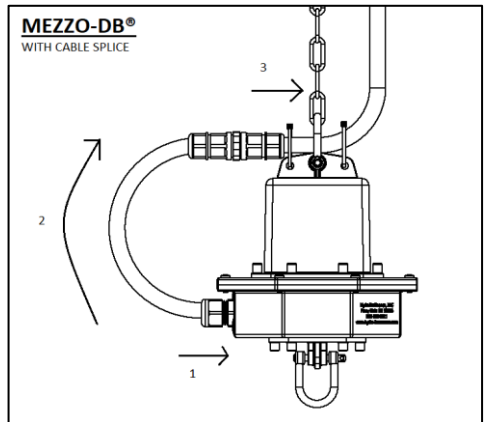
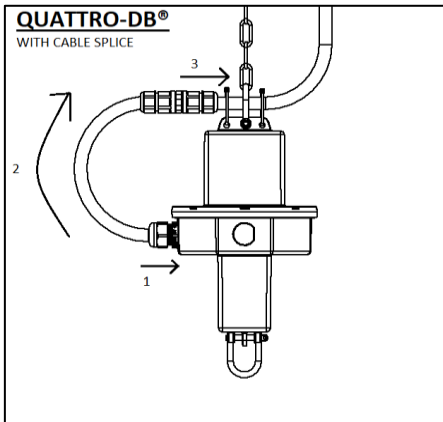

1. Use the supplied cable.
2. Slide Cable Sealing Cap (A) and Connector Housing (B) and Cable Sealing Cap Grommet (C) onto each cable.
3. Optional adhesive lined Heat Shrink tube. For very deep or high integrity protection a heat shrink tube may be used. For most typical applications, the heat shrink tube is not necessary. If using the heat shrink tube, slide the cable through it before joining the cables together.
4. To splice and join one cable to the next, align the cable colors of each cable. Red aligns with red (R-R), black to black (B-B), green to green (G-G), white to white (W-W). Refer to the RIGHT and LEFT (which is also the front and rear view) figure in **Figure-2**.
5. Prepare the ends of each cable to be joined by stripping the outer cable jacket to 0.60in (15mm) and each conductor stripped to 0.20in (5mm). Refer to the WIRE STRIP diagram in **Figure-2**.
6. Align the color of each conductor into each circuit of the Connector Splice Terminal. Use a #1 Philips screwdriver to tighten each circuit. Pull on each conductor to verify each terminal is tight in its contact circuit.
7. Thread the left side Connector Housing onto the Connector Splice Terminal fully until the red O-ring gasket (D) is fully covered.
8. Thread the left side Cable Sealing Cap onto the Connector Housing and hand tighten until fully seated.
9. Repeat these above steps for the connector parts and cable shown on the right side.
10. Secure the cable to the top mounting tab of the Sonic Head as shown in the figure above. The splice connector must be before the cable tie straps to protect the splice connector from damage.

This Cable Splice Connector was tested under 1m of water for longer than a year and provides a very secure IP68 watertight seal. The maximum outer dimension of the cable diameter is 0.35in (9mm). The maximum conductor gauge is 14ga.

The finished assembly is shown here, without the optional adhesive lined heat shrink tubing that can be added over top of the connector.



Connecting to SolaRaft and Solar Controller

For Both Types of Sonic Heads:

1. Attach the supplied chain to the center hole in the top Hanger Tab using the supplied D-Shackle as shown in the figures above.
2. Route the cable and chain up through the hole in the float with the Solar Controller.
3. Secure the chain to the eyelet at the top of the hole using the supplied carabiner clip.
4. Connect the Sonic Head Cable to the Solar Controller connector labeled SONIC 1 as shown in the photo. Route the cable through the P-clamp as shown in the photo. **IMPORTANT: Strain relief cables through the supplied P-clamps. Never allow stress to reach plug connections at the electronic modules.**
5. The Sonic Head should be approximately 0.5m to 1.5m below the surface of the water.



Dual/Second Sonic Head Installation

Refer to the 'TYPICAL APPLICATION' figure above and the figures below.

There are two alternate layouts.

Alternate Layout One: Tandem (see 'TYPICAL APPLICATION' figure above)

Consult a Limnologist to supply aid and understanding of the body of water to be treated, using this option.

For deeper lakes, a thermocline layer exists at the bottom of the lake. Algae tends to rest at this layer. By making available a second Sonic Head, positioned at this layer, it affects that algae by forcing them to move down into colder water where its life cycle may be affected and shortened.

Installing a second Sonic Head in tandem with the first Sonic Head. It is recommended that you contact HBS before proceeding to make sure the installation is done optimally. The depth of the second Sonic Head must be determined to determine the appropriate cable and chain lengths. HBS can help you with this or recommend an approved installer.

1. Install the cut end of the cable into the cable splice on the end of the cable coming out of the second Sonic Head or plug the ForteConn connector into the receptacle on the Sonic Head.

2. Secure the second Sonic Head Cable to the top Hanger Tab of the second Sonic Head with cable tie straps as shown in the figures above. The Sonic Head Cable **MUST** be secured to the holes of the Sonic Head using the supplied cable tie straps – refer to the section titled **“SECURING CABLE TO SONIC HEADS”**.



3. Secure the supplied chain to the center hole in the top Hanger Tab using the supplied D-Shackle as shown in the figures above.
4. Secure the chain for the second Sonic Head to the bottom of the first Sonic Head using a D-Shackle in the middle mounting hole in the tab. Route the cable for the second Sonic Head around the first Sonic Head as shown in the photo.

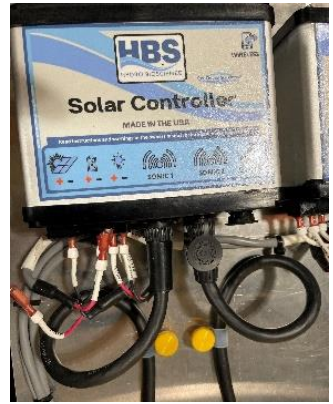

5. Route the Sonic Head Power Cable to the Solar Controller (7) and connect to Channel Two labeled ‘SONIC 2’.
6. Secure the cable using the second P-Clamp (20) and its Thumb Screw (20) as shown in the photo. **IMPORTANT: Route cables through the supplied P-clamps for strain relief. Never allow stress to reach plug connections at the electronic modules.**

Alternate Layout Two: Remote Float

The Sonic Head technology is a line-of-sight technology much like radar. The effective range of a Sonic Head is 300 meters for Blue Green Algae. From an aerial view, where the shape of the lake is a ‘V’ (or bent and not straight, i.e., a point) or an obstruction such as a fountain or aerator is used, two Sonic Heads, can provide superior coverage.

It is strongly recommended you contact HBS before proceeding to ensure optimal installation. HBS can also recommend an approved installer.

This layout requires a float kit which is purchased separately. Use manual MNUL0064-A001 to deploy the float kit with the second Sonic Head. Scan this QR Code for the latest copy of manual MNUL0064-A001.



After the float has been properly deployed with the second Sonic Head, connect the Second Sonic Head Cable to the Solar Controller in the SolaRaft. Refer to the image below and follow these steps:



1. Route the Sonic Head Power Cable up through the Float (1) hole (same hole used for the first Sonic Head) of Float (1).
2. Route the Sonic Head Power Cable to the Solar Controller (7) and connect to Channel Two labeled 'SONIC 2'.
3. Secure the cable with the 'P-Clamp' using the second P-Clamp (20) and its Thumb Screw (20). **IMPORTANT: Route cables through the supplied P-clamps for strain relief. Never allow stress to reach plug connections at the electronic modules.**

STEVEN'S WATER TELEMETRY/MODUM

The following instructions are solely for the mechanical and electrical connection to the SolaRaft product. For operation, refer to the Steven's Water Telemetry System (SWTs) Instruction Manual found on our website www.hydro-bioscience.com.

1. Due to shipping regulations, all Bluetooth devices must be turned off. The Telemetry module must first be powered on. It has a round access door at the rear. Open that access door by rotating and lifting it out of the way. Underneath is a switch. Move the switch to the 'ON' position.
2. Reinstall the access door.
3. Using the 4 screws, mount the Telemetry module on the outside of the Side Panel that doesn't have the NAV light. The connector ports on the Telemetry module must face downwards when mounting to the Side Panel.
4. There are two cables that plug into the bottom ports of the Telemetry module. The cable with two circuits threads into the first port on the left and the other end connects to the Solar Controller 'COMMS' port. Route this cable through the round hole to the right of the Telemetry module.
5. The other cable with 4 circuits plugs into the second from the left port. This 4-circuit cable electrically connects the SONDE probe to the Telemetry module. Route this cable through the round hole to the right of the Telemetry module.

SONDE PROBE

Eureka SONDE Probe Installation



Follow Eureka SONDE probe Install and operating instructions. The following steps serve as a quick guide to installing the probe into the SolaRaft. The completed installation is shown in the image.

1. Unpackage SONDE probe and unscrew the protective cap.
2. Connect SONDE cable by threading and hand tightening the cable plug.
3. Locate the hardware package labeled 'Bail Hanger'.
4. Thread the 1/4in eyebolts to the Probe.
5. In the Spare Parts Bag supplied with the SolaRaft, retrieve the stainless-steel chain and carabiner clip (1 needed).
6. Weave the last link of the chain through the hanger and then weave the hanger over the two eyebolts. Using a wrench, tighten the nuts on the 1/4in eyebolt. Do not overtighten!
7. Using the carabiner clip, weave it through a link in the chain and then fasten it to the 5/16in eyebolt threaded into the Float.
8. Drop the probe down the 100mm (4in) access hole of the Float.
9. Adjust the chain length to desired probe depth.
10. The depth of the probe, as determined by the length of chain, is typically set such that the bottom of the probe protrudes through the hole 305mm (1ft) below the bottom surface of the Float or greater.
11. Follow the manufacturer's cleaning and calibration routine before deploying.

3. Operation

HOW TO OPERATE SONIC HEADS

Solar Powered Systems



Solar Charger and Controller Power Supply

For operation of Sonic Heads using the Solar Controller, please refer to the Solar Charger/Controller User's Manual (MNUL0059-A001) or visit the resources → manual section at <https://www.hydro-bioscience.com/>. The third port also accepts a Lockout Key Connector used to shut down the system for shipping or storage reasons.

Each sonic powered output connector port is labeled 'Sonic1' and 'Sonic2':



Sonic1 Connector does not ship with a dust cover, but Sonic2 Connector must have its dust cover popped off if a second sonic head cable is connected to it.

WHAT TO EXPECT AFTER INSTALLATION

Most Blue-Green algae (and cyanobacteria) will have lost their buoyancy and should be on, or settling, to the pond bottom within 3-4 days. The cells can be re-suspended via aeration bringing them up to the light which may prolong the time it takes for them to fully die off. Therefore, please note that a subsequent "bloom" is not uncommon, and it could take multiple cycles before a thorough algae remediation can occur.

Green algae (filamentous types) and colonial types require up to 3+ weeks before the damage results in them turning brown, depending on the kind (genus) of algae. They will normally float to the surface at this time due to the bacterial digestion process breaking them down. It takes about 7-10 days from that point before they are sufficiently digested to lose buoyancy and sink. Some users rake them out as the die-off begins or you may just let them settle to the bottom. If you do the latter, bioaugmentation can speed up the digestion process and help remove the biomass.

Diatoms react similarly to green algae but lose mobility quickly which hastens their dying process.

For Bio-Film Control and prevention for water processing or treatment equipment, the ultrasound will be sensed by anaerobic bacteria as water turbulence. This will prevent the anaerobes from attempting colonization in a treated zone. Anaerobes start the process by forming a base layer of biofilm that the aerobic bacteria attach themselves to. Without this layer the bacteria cannot accumulate which, in turn, keeps the equipment walls cleaner for longer periods of time.

SONIC HEAD MAINTENANCE

The Hydro BioScience® ultrasound algae management system is designed to limit calcium carbonate crystal formation on the sound emitting surfaces, so it forms slowly. Over time, buildup will occur depending on how hard the water is where the SolaRaft is deployed. Check the system for any Calcium Carbonate buildup after the first month of operation. If you see significant crystalline formation, use a Calcium Lime Rust remover to wipe it away. Adjust your cleaning cycle based on how quickly the buildup returns.

Early field results show that biofilm formation on the device is likely. This has been seen on other ultrasonic devices in that the sound they emit away from the device tends to prevent biofilm everywhere except for directly on the device (ground zero for the sound emission). For water treatment facilities, it is recommended that the Sonic Head gets wiped or brushed off monthly to remove any accumulated biofilm. The biofilm has not been shown to cause loss of output from the Sonic Head because ultrasound seems to easily pass through the film (since it is about 99% water).

Winterization: If your pond ices over during the winter, it is best to pull the transducer and float assembly out of the water to prevent ice buildup from damaging the cable or other system components. Thoroughly dry all components before storing. Reapply dielectric grease (included with the Transducer assembly) grease to any cable ends that were disconnected.

4. Appendix

SOLARAFT STORAGE AND RE-DEPLOYMENT

Storage

If, due to seasonal cold where temperatures dip to less than 5°C (40°F) over an extended period of time, it becomes necessary to store the product, follow this procedure. Also refer to the section titled "[PRODUCT FEATURES](#)" for reference to the product numbered features.

1. Pull SolaRaft system close to shore. Remove the 4 Solar Panel Lock Screws and swing open the Solar Panels to gain access to components.
2. If fitted with a SONDE probe, mechanically unseat it from the Float and rest it on the Float. It does not need to be electrically disconnected. With probe unseated, the Solar Panels can be swung closed and the SolaRaft can be pulled completely onto shore or onto a dock.
3. Disconnect the Anchor D-Shackle from the Anchor Rope or Anchor Chain.
4. Swing the Solar Panels open again, once on firm ground.
5. Reach underneath the Float to pull the Sonic Head up and over the Side Plate and allow the Sonic Head to rest on top of the Float.
6. Find the Solar Controller and locate the Battery Positive Terminal. Disconnect this lead by pulling it out. Fill the terminal with Dielectric Grease. Leave the terminal unconnected.
7. Swing the Solar Panels closed. Re-install the 4 Solar Panel Lock Screws
8. With the battery terminal unconnected, all other electrical connections, including the Solar Panel connection, may be left connected.
9. The SolaRaft and its battery pack may now be left in storage for a year or longer.
10. If a SONDE Probe is used, follow the manufacturer's cleaning and calibration routine before moving into storage.

Redeployment

1. From storage and prior to redeployment, clean the SolaRaft. Gently spray off dirt and debris using a water hose.
2. Wipe the solar panels using a common household window cleaner and a soft cloth.
3. Swing the Solar Panels open. Re-install the 4 Solar Panel Lock Screws
4. Reconnect the Positive Battery Terminal Fast-on to the Solar Controller Positive Battery Input tab terminal.
5. The NAV light will begin flashing.
6. Reverse the procedure from 'Storage' above.
7. If a SONDE Probe is used, follow the manufacturer's cleaning and calibration routine before deploying.
8. Swing the Solar Panels closed. Re-install the 4 Solar Panel Lock Screws.
9. Redeploy

TYPICAL SOLARAFT CIRCUIT CONNECTION

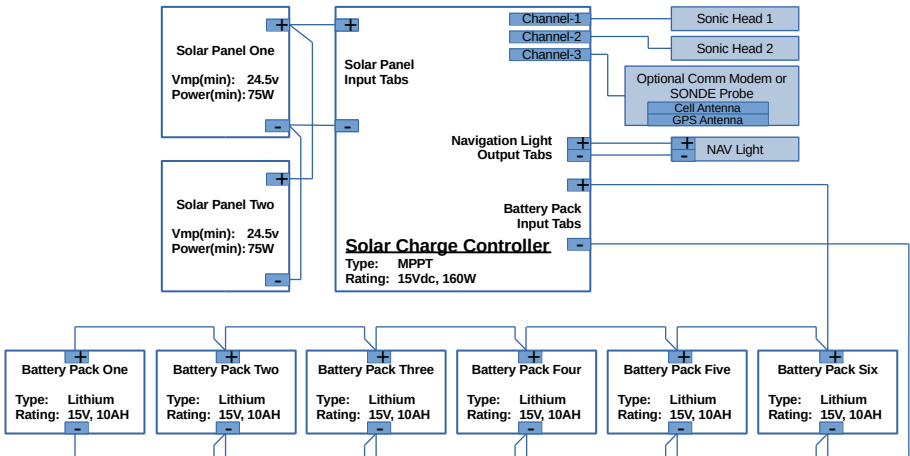

AFFECTED ALGAE SPECIES*

Aphanizomenon, Cyclotella, Pseudanabaena, Anabaena, Dictyosphaerium, Phacus, Aphanochaete, Fragilaria, Pinnularia, Arcella, Gloeocystis, Planktothrix, Gomphonema, Chlamydomonas, Lagerheimia, Chlorella, Lyngbya, Chroococcus, Micractinium, Spirogyra, Coelastrum, Staurastrum, Microcystis, Cosmarium, Tabellaria, Crucigenia, Nitzschia, Tribonema, Ulothrix, Botryococcus braunii, Rhodomonas minuta, Tetrademus acuminatus, Scenedesmus quadricauda, Merismopedia tenuissima, Sphaerocystis Schroeteri, Chloromonas reticulata, Navicula minima, Cryptomonas erosa, and Oocystis pusilla

*This is not a complete list of algae that is affected by HBS Ultrasonic systems



Important Note: Certain species of plants and foliage rely on the presence of biofilm to survive and may be adversely affected. One known species affected is water hyacinth (*Pontederia crassipes*). Therefore, the sonic head devices are registered with the EPA.

Typical Area Coverage:

Blue-Green Algae:	approximately 120 acres
Green Algae:	approximately 17 acres
Biofilm:	approximately 3 acres

PRODUCT DIMENSIONS

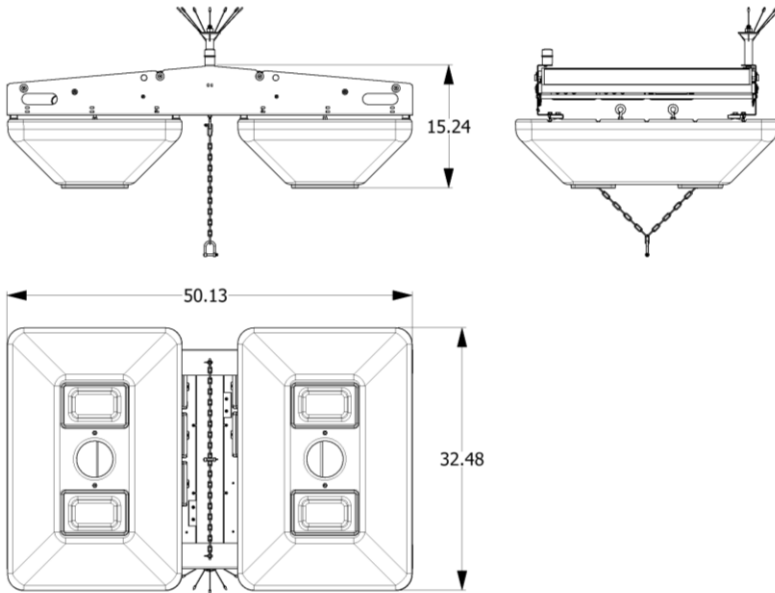

5. General Warranty

Hydro BioScience, LLC (HBS) warrants that the product will be free from defects in materials and workmanship for a period of 3 years (1 year for accessories) from the date of purchase of the product by the original purchaser from HBS. This warranty only applies to the original purchaser and is not transferable to the third party.

If the product proves defective during the warranty period, HBS either will repair the defective product without charge for parts and labor or will provide a replacement in exchange for the defective product. Parts, modules, and replacement products used by HBS for warranty work may be new or reconditioned like new performance. All replaced parts, modules and products become the property of HBS.

To obtain service under this warranty, customer must notify HBS of the defect before the expiration of the warranty period. Customer shall be responsible for packaging and shipping the defective product to the service center designated by HBS, and with a copy of customer proof of purchase. Customer must ensure that an RMA (Return Material Authorization) number has been received from HBS. This RMA number must be printed on outside of the return packaging.

This warranty shall not apply to any defect, failure or damage caused by improper use or improper or inadequate maintenance and care. HBS shall not be obligated to furnish service under this warranty:

- a) to repair damage resulting from attempts by personnel other than HBS representatives to install, repair or service the product;
- b) to repair damage resulting from improper use or connection to incompatible equipment;
- c) to repair any damage or malfunction caused by the use of non-HBS supplies;
- d) to service a product that has been modified or integrated with other products when the effect of such modification or integration increases the time or difficulty of servicing the product.

Please contact the nearest HBS's Sales and Service Offices for services. For better after-sales service, please visit www.hydro-bioscience.com and register the purchased product online. Warranty may also be requested on-line, along with obtaining an RMA, automatically.

Excepting the after-sales services provided in this summary or the applicable warranty statements, HBS will not offer any guarantee for maintenance declared or hinted, including but not limited to the implied guarantee for marketability and special-purpose acceptability. HBS should not take any responsibility for any indirect, special, or consequent damages.

For Customer Service, and to request an RMA or obtain Return Information, please call Hydro Bioscience, LLC at 888-500-5011.

For all returns, clearly mark the RMA # on the outside of the packaging and send to:

Hydro Bioscience, LLC
414 Century Court
Piney Flats, TN 37686
RMA Number: _____