

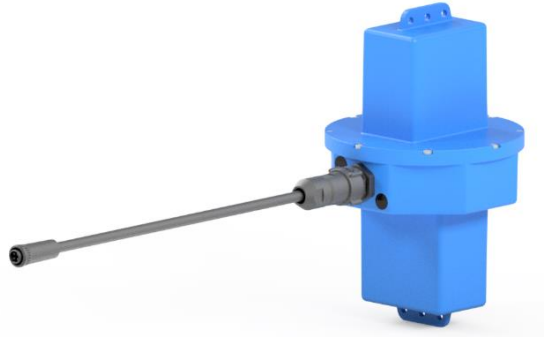

Quattro-DB® blu Sonic Head and Flotation System 40AC-264CU7 Series



General Product Specifications

Model Number	Input Power	Product Description
40AC-264CU7AF-H00	40Vdc	360° Coverage, ForteConn® Connector

EPA Co. No. 95328, Patent No. 10399867

NOTE: ADDITIONAL UTILITY AND/OR PATENT PENDING APPLIED IN 2022-2024



For direct access to the latest copy of this manual,
please scan this QR Code or refer to the *Product
Manuals* section at:

www.Hydro-Bioscience.com

Table of Contents

























1. <i>Safety Information</i>	3
SAFETY SYMBOLS AND TERMS	3
Safety Symbols	3
Safety Terms	3
GENERAL SAFETY REQUIREMENTS	4
User Safety and General Product Precautions	4
Uses	4
Limitations and Disclaimers	4
2. <i>Installation</i>	5
PRODUCT FEATURES	5
PRODUCT ASSEMBLY	5
SONIC HEAD CABLE CONNECTION	6
Connecting Cable to Sonic Heads	6
ANCHOR AND SONIC HEAD PLACEMENT	7
3. <i>Operation</i>	8
POWER SUPPLY	8
24Vac/Vdc Low Voltage Utility Power Supply	8
Powering System	8
WHAT TO EXPECT AFTER INSTALLATION	8
Blue-Green Algae (Cyanobacteria)	8
Green Algae	8
Diatoms	9
Biofilm	9
Affected Algae Species	9
Typical Area Coverage:	9
SONIC HEAD MAINTENANCE	9
Storage	10
Redeployment	10
4. <i>Appendix</i>	11
PRODUCT DIMENSIONS	11
SPECIFICATIONS	11
5. <i>General Warranty</i>	12

1. Safety Information

SAFETY SYMBOLS AND TERMS

Safety Symbols

The following symbols may appear on the product:

	Direct current (DC)		Caution, risk of danger
	Alternating current (AC)		Warning, risk of electric shock
	Both direct & alternating current		Risk of explosion
	Ground terminal		Recycle lithium-ion batteries
	Chassis ground		Do not incinerate
	Power on/off		Power port
	Battery/cell power connection		Battery/cell power connection
	Communication port		Solar panel port
	Repair/service		AC connection port
	Navigation light connection		MyQuattro App communication
	Conforms to European Union directives		
	Complies to the Federal Communications Commission		
	Complies with the Restriction of Hazardous Substances Directive (2002/95/EC)		
	This product complies with the WEEE Directive (2002/96/EC) marking equipment. The affixed product label indicates that you must not discard this electrical/electronic product in domestic household waste.		

Safety Terms

Terms in this manual:

 Warning/Caution: 'BE ALERT – YOUR SAFETY IS INVOLVED'. If you do not follow these safety instructions, personal injury, loss of life, and/or property damage may occur.

Terms on the product:

Danger: Indicates an immediate hazard which will result in death or serious injury.

Warning: Indicates a hazard which may result in death or serious injury.

Caution: Indicates a hazard which may result in minor or moderate injury.

GENERAL SAFETY REQUIREMENTS

 **WARNING - Read this manual thoroughly before using the product.**

User Safety and General Product Precautions

1. Locate/route all cords where they will not be tripped over or damaged by vehicles or equipment with cutting blades such as lawn mowers and hedge clippers and away from vehicle/boat traffic to prevent being driven over.
2. When deploying, follow all equipment and vehicle (such as boats, rafts) operator safety manual instructions.



3. Installation and working in and around water always requires 2 or more individuals for safety.
4. If wildlife such as beavers, minks, nutria, otters, muskrats, turtles, etc., are present in the water body, additional cable protection is recommended such as a nylon or polyester braided sheath from the surface down to about 2 meters (6 feet) depth.
5. Other manuals included with this manual, such as battery, solar controller/charger, Sonic Head, and SolaRaft manuals must be read fully. Comply with all safety precautions in those manuals. This manual contains only assembly excerpts from these other manuals. **Visit our website www.hydro-bioscience.com to locate these manuals. Alternately, download the manuals by scanning the QR code shown on the white label located on the top of the Power Supply.**

Uses

The HBS Algae Remediation Products treat bodies of water such as lakes, ponds, etc. as an aid in preventing, reducing, and in many cases eradicating harmful algal blooms.

Limitations and Disclaimers

Due to environmental and manmade conditions contributing to excessive nutrient loading and many other factors, varying degrees of product efficacy should be expected and therefore, there is no guarantee regarding the total prevention or eradication of algae or algal blooms. HBS Algae Remediation products do not treat any body of water to produce potable or drinkable water. HBS Algae Remediation Products do not treat for other bacterium, pollution, viruses, toxins, micro-organisms, or other matter which may be present, and other methods of trea®ent may be needed to provide prevention, remediation, or elimination of such. HBS Algae Remediation Products are not a replacement for other water treatment methods, including, but not limited to, aeration, chlorination, oxidation, skimming, or other treatments meant to prevent, reduce, or eliminate other bacterium, pollution, viruses, micro-organisms, or other matter which may be present. HBS Algae Remediation Products are not to be utilized for off-label or unintended uses. Such off-label or unintended use may void the product's warranty and/or cause damage to persons or property.

2. Installation

PRODUCT FEATURES

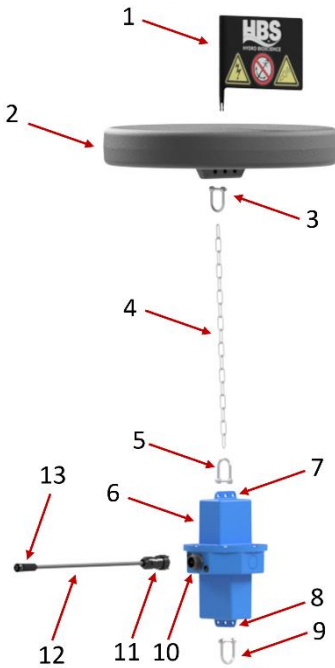

1. Warning Flag
2. Float
3. D-Shackle
4. Chain
5. D-Shackle
6. Quattro-DB® blu Sonic Head
7. Sonic Head's Top Hanger
8. Sonic Head's Bottom Hanger
9. D-Shackle
10. ForteConn® Power Receptacle – male pins
11. ForteConn® Power Plug – female socket
12. Power Cable
13. Power Supply Plug

PRODUCT ASSEMBLY

Refer to [PRODUCT FEATURES](#) figure and related call-out numbers. The call-out numbers are referenced in parenthesis.

1. Place the post of the flag (1) (if supplied) into the center hole of float (2) and push down hard enough until the post of the flag snaps into place.
2. Reference the three holes of the hanger below the float (2). Use the D-shackle (3) to attach the upper most link of chain (4) to the center hole of the float's hanger.
3. Use the D-shackle (5) to attach the bottom link of chain (4) to the center hole of the sonic head's top hanger (7).
4. Mount power supply in a secure, dry location (or secure in a NEMA enclosure) using appropriate screws provided in hardware bag.

SONIC HEAD CABLE CONNECTION



If a cable connector is supplied which connects to a power supply, apply a very small 3mm diameter spot or less of dielectric grease to all socket contacts – not pins. This protects from corrosion, moisture, and dirt when connectors are disconnected. Any dielectric grease or lubricant used must conform to NSF-61 Marine Grade standards.

Connecting Cable to Sonic Heads

To avoid a non-warranty claim, follow the installation instructions below.



NEVER USE THE STRAIN RELIEF LOOP OR THE POWER CONNECTOR AS A HANDLE. ALWAYS USE THE CHAIN ON THE TOP OF THE UNIT WHEN LIFTING THE SONIC HEAD.

1. Use the supplied power cable (12).
2. Apply 3mm diameter spot of dielectric grease to the power supply cable port AND ForteConn® Power Plug (11) to aid in the resilience to moisture, dirt, and grime.
3. Plug the cable into the power supply and attach the ForteConn® Plug (11) to the ForteConn® Receptacle (10) and tighten until fully seated.
4. Make a strain relief loop for the power cable (12) by making a radial bend and secure it to the two outer holes of the sonic head's bottom hanger (8) with supplied cable ties (as shown). Clip off excess cable tie straps with flush cut trimmers or scissors. **Always secure the cable to the Sonic Head using cable tie straps to prevent damage to the ForteConn® connector.**
5. Attach the D-shackle (9), around the power cable (12), and secure to the center mounting hole on the sonic head's bottom hanger (8).
6. The cable is typically allowed to lay along the bottom of the lakebed out to shore and connected to a power supply designed to drive the Sonic Head.

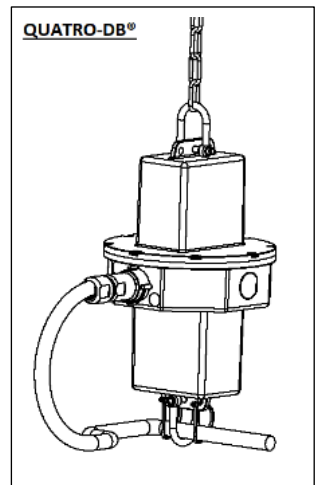

- When laying the cable in shallow water less than 2m [\sim 6ft], and over shore ground it may be beneficial to sheath the cable or bury it to deter wildlife from biting and severing the cable or pulling the cable.

IMPORTANT: At shore, it is important to secure the cable with a stress relief so that wildlife pulling on the cable will not transmit that pull to the power supply connector on shore.

ANCHOR AND SONIC HEAD PLACEMENT

TYPICAL APPLICATION

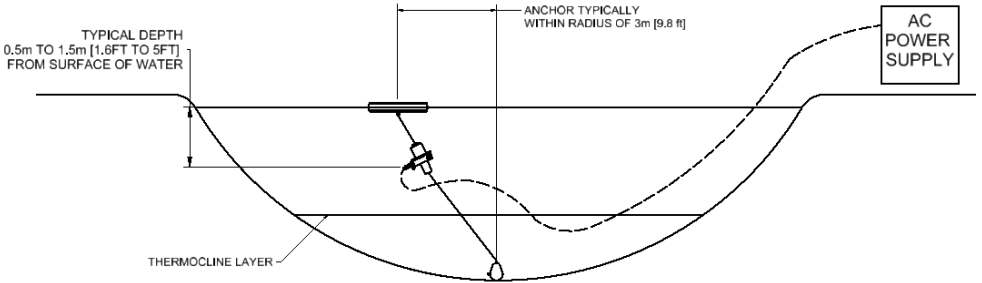

Where one Sonic Head is used, refer to the image above.

- A typical 2.27kg (5lb) anchor ball, available from many sources including marinas and retail stores, is needed to keep the system in place. The anchor is first tied to a marine grade rope, stainless-steel cable, or a chain and dropped until it rests on the lakebed. (Alternatively, cinder blocks or other heavy weights can be considered for the anchor.)
- Adjust the anchor line so the anchor is resting on the lakebed with 2m [6.56ft] excess line above water surface, from where the anchor/system is to be placed.
- The top end of the anchor line should then be secured to the bottom D-shackle (9).

3. Operation

POWER SUPPLY

24Vac/Vdc Low Voltage Utility Power Supply



For operation of Sonic Heads using the 24V AC/DC Power Controller, please refer to the 24V AC/DC Power Supply User's Manual (MNUL0058-A001) or visit the resources → manual section at <https://www.hydro-bioscience.com/>

Powering System



1. Locate power supply plug (as shown) and connect to power supply.
2. Locate your country's correct wall adaptor.
3. Snap the correct wall adaptor onto the power brick.
4. Plug into AC power receptacle (100-240V 50/60Hz) to power sonic head system.

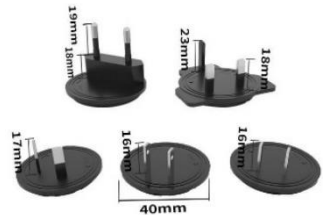

WHAT TO EXPECT AFTER INSTALLATION

Blue-Green Algae (Cyanobacteria)

Most blue-green algae (cyanobacteria) will have lost their buoyancy and should be on, or settling, to the pond bottom within 3-4 days. The cells can be re-suspended via aeration bringing them up to the light which may prolong the time it takes for them to fully die off. Therefore, please note that a subsequent "bloom" is not uncommon, and it could take multiple cycles before a thorough algae remediation can occur.

Green Algae

Green algae (filamentous types) and colonial types require up to 3+ weeks before the damage results in them turning brown, depending on the kind (genus/species) of algae. They will normally float to the surface at this time due to the bacterial digestion process breaking them down. It takes about 7-10 days from that point before they are sufficiently digested to lose buoyancy and sink. Some users rake them out as the die-off begins or you may just let them settle to the bottom. If you do the latter, bioaugmentation can speed up the digestion process and help remove the biomass.

Diatoms

Diatoms react similarly to green algae but lose mobility quickly which hastens their dying process.

Biofilm

For biofilm control and prevention, ultrasonic frequencies mimic turbulent water which prevents the colonization of microorganisms in biofilm forms.

Affected Algae Species

Achnantheidium minutissimum, Anabaena spp., Ankistrodesmus falcatus, Aphanizomenon spp., Aphanochaete spp., Botryococcus braunii, Chlamydomonas spp., Chlorella spp., Chloromonas botrys, Chroococcus spp., Closterium spp., Cocconeis placentula, Coelastrum spp., Cosmarium spp., Crucigenia spp., Cryptomonas erosa, Cryptomonas spp., Cyanobium sp., Cyclotella spp., Desmodesmus abundans, Dictyosphaerium spp., Fragilaria capucina, Fragilaria spp., Gloeocystis spp., Gomphonema parvulum, Gomphonema spp., Heteroleibleinia spp., Lagerheimia spp., Leptolyngbya spp., Lyngbya spp., Merismopedia tenuissima, Micractinium spp., Microcystis spp.*, Navicula minima, Nitzschia spp., Oedogonium spp., Oocystis pusilla, Oocystis spp., Phacus spp., Pinnularia spp., Pithophora spp.*, Plagioselmis nannoplantica, Planktothrix spp., Planothidium lanceolatum, Polycystis sp., Pseudanabaena spp., Raphidiopsis raciborskii*, Scenedesmus quadricauda, Sphaerocystis schroeteri, Spirogyra spp., Staurastrum spp., Stigeoclonium spp., Tabellaria spp., Tetrademus lagerheimii, Tribonema spp., Ulnaria ulna, Ulothrix spp.

*Only partial control

(This is not a complete list of algae that is affected by HBS Ultrasonic systems)

 **Important Note: Certain species of plants and foliage rely on the presence of biofilm to survive and may be adversely affected. One known affected species is water hyacinth (Pontederia crassipes). Therefore, the sonic head devices are registered with the EPA.**

Typical Area Coverage:

Blue-Green Algae:	approximately 60 acres
Green Algae:	approximately 8.75 acres
Biofilm/Diatoms:	approximately 1.5 acres

SONIC HEAD MAINTENANCE

The HBS ultrasonic algae management system is designed to limit calcium carbonate crystal formation on the sound emitting surfaces, so it forms slowly. Over time, buildup will occur depending on how hard the water is where you live. Check the system for any calcium carbonate buildup after the first month of operation. If you see significant crystalline formation, use a calcium lime rust remover to wipe it away. Adjust your cleaning cycle based on how quickly the buildup returns.

Early field results show that biofilm formation on the device is likely. This has been seen on other ultrasonic devices. This is due to ultrasonic frequencies mimicking turbulent water and preventing biofilm colonization everywhere except for directly on the device (ground zero for the sound emission). For water treatment facilities, it is recommended that the sonic head gets wiped or brushed off monthly to remove any accumulated biofilm. Small accumulation of biofilm has not been shown to cause loss of output from the sonic head because ultrasound seems to easily pass through the film (since it is about 99% water), but if left uncleaned, large buildup of biofilm will cause dampening of ultrasonic frequencies and limit the effectiveness of the device.

Storage

Winterization: If your pond ices over during the winter or if temperatures drop to less than 5°C (40°F) over an extended period of time, it becomes necessary to store the sonic head and float assembly to prevent ice buildup from damaging the cable or other system components.

1. Unplug the power supply and make sure the system is fully powered off.
2. Locate anchor chain and disconnect from lower D-shackle (9). Make sure to secure the anchor line or remove anchor from water body to use for redeployment.
3. Pull system to shore and out of water body.
4. Unplug cable from power supply.
5. Thoroughly dry system before storage.
6. Store system in safe, dry location.

Redeployment

1. Prior to redeployment, clean the sonic head. Gently spray off dirt and debris using a water hose or wipe with a wet, soapy cloth.
2. Reapply dielectric grease to cable connections.
3. Plug cable into power supply.
4. Reattach anchor line to d-shackle (9).
5. Redeploy.
6. Plug in power supply to AC receptacle after redeployment.

4. Appendix

PRODUCT DIMENSIONS

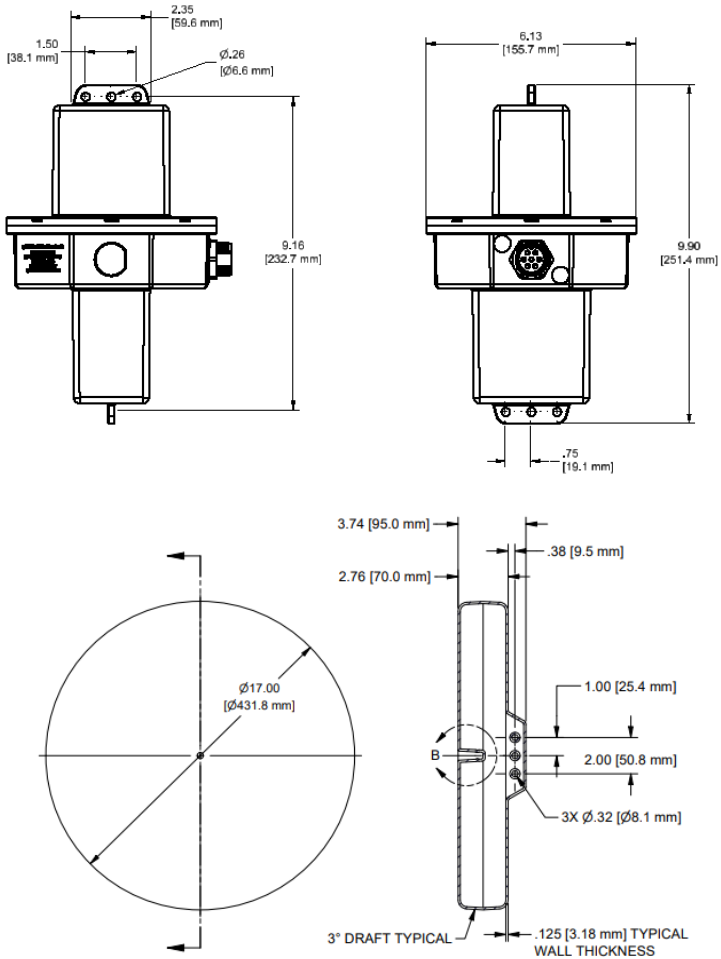

SPECIFICATIONS

Parameter	Specification	Notes/Descriptions
Nominal Input Rating:	32Vdc to 48Vdc, 15W	
Ingress Rating, Enclosure:	IP-68 minimum	
Ingress Rating, Connectors:	IP-68 minimum	
Dimension, mm, in:	155.7x251.4mm, 6.13x9.90in	
Weight, kg, lb:	3.15kg, 7lbs	
Frequency Range:	20kHz to 210kHz	
Operating Temperature:	-10°C to 65°C, 14°F to 149°F	
Storage Temperature:	-40°C to 85°C, -40°F to 185°F	

5. General Warranty

Hydro BioScience, LLC (HBS) warrants that the product will be free from defects in materials and workmanship for a period of 1 year from the date of purchase of the product by the original purchaser from HBS. This warranty only applies to the original purchaser and is not transferable to the third party.

If the product proves defective during the warranty period, HBS either will repair the defective product without charge for parts and labor or will provide a replacement in exchange for the defective product. Parts, modules, and replacement products used by HBS for warranty work may be new or reconditioned like new performance. All replaced parts, modules and products become the property of HBS.

To obtain service under this warranty, customer must notify HBS of the defect before the expiration of the warranty period. Customer shall be responsible for packaging and shipping the defective product to the service center designated by HBS, and with a copy of customer proof of purchase. Customer must ensure that an RMA (Return Material Authorization) number has been received from HBS. This RMA number must be printed on outside of the return packaging.

This warranty shall not apply to any defect, failure or damage caused by improper use or improper or inadequate maintenance and care. HBS shall not be obligated to furnish service under this warranty:

- a) to repair damage resulting from attempts by personnel other than HBS representatives to install, repair or service the product;
- b) to repair damage resulting from improper use or connection to incompatible equipment;
- c) to repair any damage or malfunction caused by the use of non-HBS supplies;
- d) to service a product that has been modified or integrated with other products when the effect of such modification or integration increases the time or difficulty of servicing the product.

Please contact the nearest HBS's Sales and Service Offices for services. For better after-sales service, please visit www.hydro-bioscience.com and register the purchased product online. Warranty may also be requested on-line, along with obtaining an RMA, automatically.

Excepting the after-sales services provided in this summary or the applicable warranty statements, HBS will not offer any guarantee for maintenance declared or hinted, including but not limited to the implied guarantee for marketability and special-purpose acceptability. HBS should not take any responsibility for any indirect, special, or consequent damages.

For Customer Service, and to request an RMA or obtain Return Information, please call Hydro Bioscience, LLC at 888-500-5011.

For all returns, clearly mark the RMA # on the outside of the packaging and send to:

Hydro Bioscience, LLC
414 Century Court
Piney Flats, TN 37686
RMA Number: _____

